

DATA SHEET

# GEN series GN310B (GN311B)

## 3 channel power card $\pm 1500$ V DC CAT III and $\pm 2$ A

### SPECIAL FEATURES

- Accuracy 0.015% of reading, 0.02% of range
- 3 power channels (U and I)
- 5 voltage ranges up to  $\pm 1500$  V DC CAT III
- 7 current ranges up to  $\pm 2$  A
- 2 Digital channels for torque and speed
- Real-time computations of RMS, P, S, Q,  $\lambda$ ,  $\eta$ ,  $\cos\phi$ , THD,  $i_{\alpha}$ ,  $i_{\beta}$  and more
- Full bandwidth power calculations
- Fundamental power calculations
- Phase matched anti-alias protection
- 1 ms latency real-time output
- 18 bit at 2 MS/s (200 kS/s) sample rate
- Triggering on real-time power results

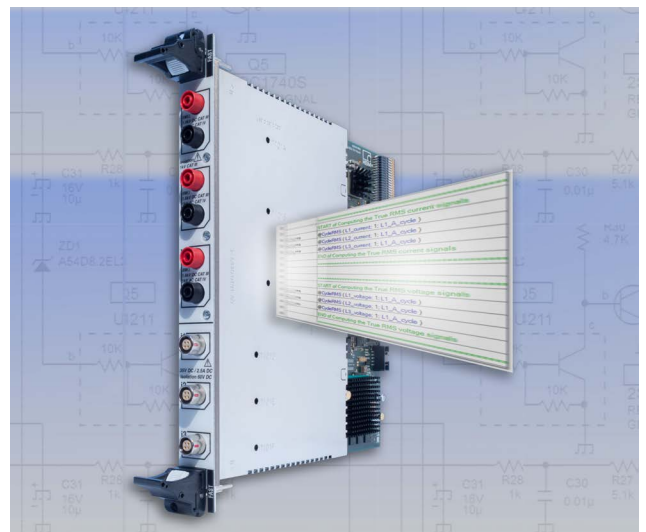

### GN310B/GN311B Functions and Benefits

The power card GN310B offers three power channels, each one consisting of one voltage input and one current (or voltage) input.

The voltage inputs start at  $\pm 50$  V to  $\pm 1500$  V in five ranges, allowing to scale the inputs to best match your signal level to achieve minimum measurement uncertainty.

The voltage input isolation is tested up to 7.4 kV RMS supporting safe measurements up to 1000 V RMS CAT IV and 1500 V DC CAT III.

The current inputs start at  $\pm 75$  mA to  $\pm 2$  A, in seven range and uses internal burden resistors to support all common zero flux current transducers on the market.

All current inputs can be switched to "voltage mode" to connect current clamps or Rogowski coils.

The current inputs are electrically isolated up to 60 V to avoid current loops.

Full wide band power measurements allows for optimum efficiency calculations, where the optional unique multi stage anti-alias digital Bessel / Butterworth or Elliptic filters using 11 or 12 orders guarantees superior phase match, ultra-low noise and alias free results in noisy environments.

The four Timer/Counters and the G070A torque/RPM adapter allow for direct interfacing to HBK torque transducers or other torque and speed sensors.

The real-time formula database offers predefined or custom analysis. Power calculations like RMS, P, Q, S,  $\cos\phi$ ,  $\lambda$ , or  $\eta$  come out of the box, be it for wideband signals or the fundamental only. Advanced formulas allow real-time transformations to obtain  $\alpha$  and  $\beta$  space vectors or d, q currents of an electric drive system. All results can be transferred to an automation system in real-time using GEN DAQ API and the optional CAN FD or EtherCAT® (1 ms latency) interfaces of the mainframe.

Capabilities Overview		
Model	GN310B	GN311B
Maximum sample rate per channel	2 MS/s	200 KS/s
Memory per card	2 GB	
Analog channels	6	
Anti-alias filters	Fixed bandwidth analog AA-filter combined with sample rate tracking digital AA-filter	
ADC resolution	18 bit	
Isolation	Channel to channel and channel to chassis	
Input type	High voltage: analog, isolated, balanced differential Current / low voltage: analog, isolated, unbalanced differential	
Passive voltage/current probes	Voltage channels support special designed matching probes only Current channels in voltage mode support current probes	
Sensors	Current channels in current mode support current transducers	
TEDS	Not supported	
Real-time formula database calculators (option)	Extensive set of user programmable math routines with triggering on calculated results	
Digital Event/Timer/Counter	16 digital events and 4 Timer/Counter channels	
Standard data streaming (CPCI up to 200 MB/s)	Not supported	
Fast data streaming (PCIe up to 1 GB/s)	Supported	
Slot width	1	

Mainframe Support						
	GEN2tB	GEN4tB	GEN7tA / GEN7tB	GEN17tA / GEN17tB	GEN3iA	GEN7iA
GN310/GN311B	Yes					
GEN DAQ API	Yes				Yes <sup>(1)</sup>	
EtherCAT®	No	Yes			No	
CAN/CAN FD	Yes				No	

(1) Close Perception to enable GEN DAQ API access.

## Supported Analog Sensors and Probes

Amplifier mode	Supported analog sensors and probes	Features, Cabling and Accessories
Power measurement	<ul style="list-style-type: none"> <li>Current transducers</li> <li>Current probes</li> <li>Electrical voltages single-ended and differential</li> <li>Active single-ended voltage probes</li> <li>Active differential voltage probes</li> </ul>	<ul style="list-style-type: none"> <li>3 Power channels (Voltage and Current)</li> <li>Voltage input: <math>\pm 50</math> V up to <math>\pm 1500</math> V</li> <li>Direct current input for: <math>\pm 75</math> mA up to <math>\pm 2.0</math> A</li> <li>Voltage as current input: <math>\pm 50</math> mV up to <math>\pm 20</math> V</li> <li>5 kV RMS certified probe</li> <li>Current probes</li> </ul>

## Supported Digital Sensors (TTL Level Input)

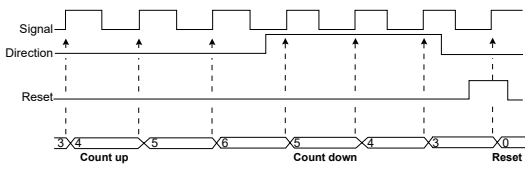
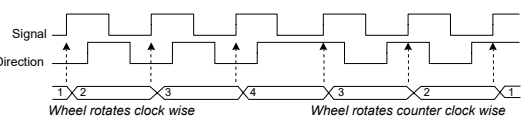
Timer counter Input type	Supported digital sensors	Features
 <p><b>Figure 1: Uni and Bi-directional clock</b></p>	<ul style="list-style-type: none"> <li>HBK Torque sensors</li> <li>Torque sensors</li> <li>Speed sensors</li> <li>Position sensors</li> </ul>	<ul style="list-style-type: none"> <li>Angle measurement</li> <li>Frequency / RPM measurement</li> <li>Count/position measurement</li> <li>Count frequency up to 5 MHz</li> <li>Digital filter on input signals</li> <li>Several reset options</li> <li>RT-FDB can add a calculated Frequency/RPM channel based on the angle measurement</li> </ul>
 <p><b>Figure 2: ABZ Incremental Encoder (Quadrature)</b></p>	<ul style="list-style-type: none"> <li>HBK Torque sensors</li> <li>Torque sensors</li> <li>Speed sensors</li> <li>Position sensors</li> </ul>	<ul style="list-style-type: none"> <li>Angle measure</li> <li>Frequency / RPM measurement</li> <li>Count/position measurement</li> <li>Count frequency up to 2 MHz</li> <li>Digital filter on input signals</li> <li>Single, dual and quad precision count</li> <li>Transition tracking to avoid count drift</li> <li>Several reset options</li> <li>RT-FDB can add a calculated Frequency/RPM channel based on the angle measurement</li> </ul>

Block Diagram

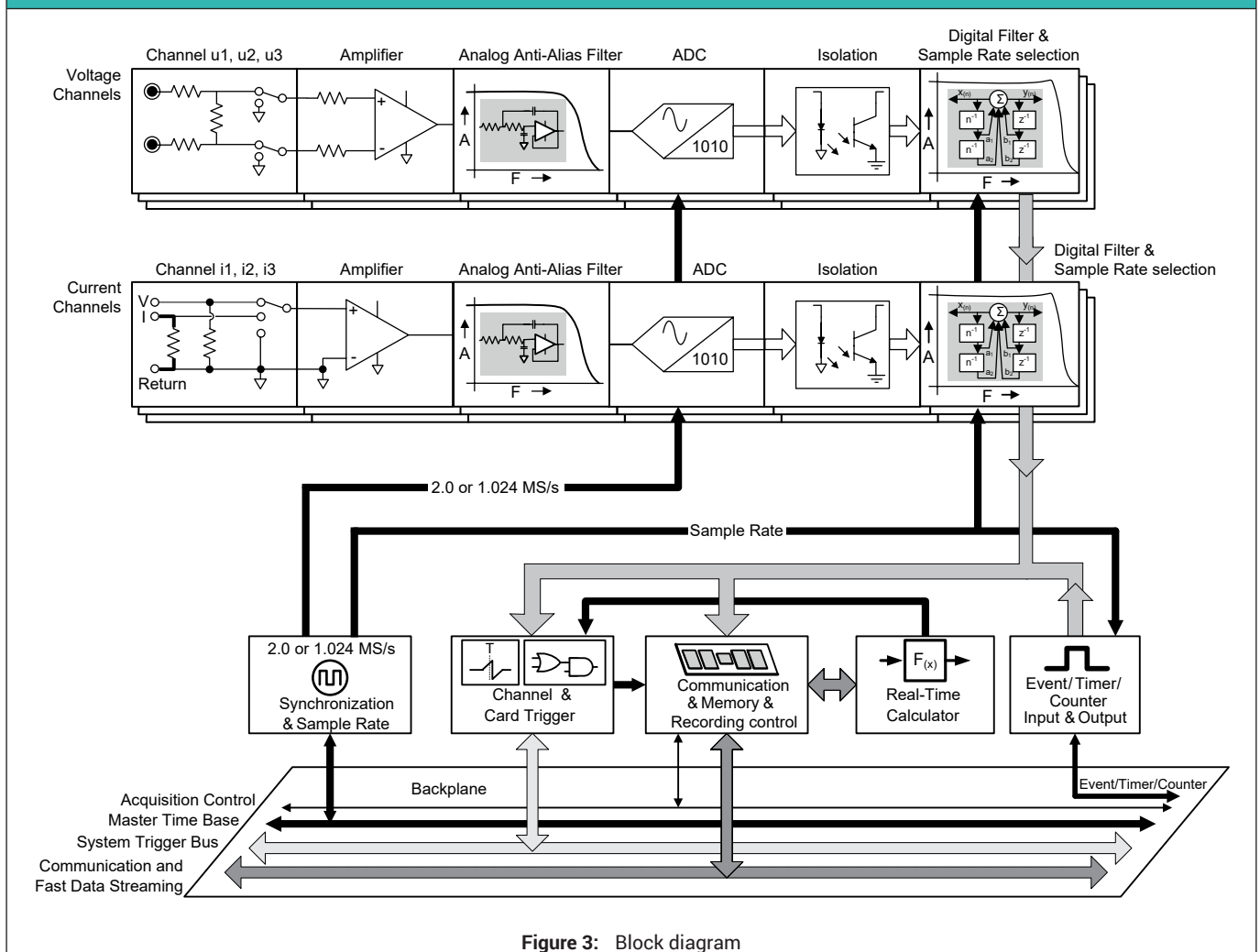

Figure 3: Block diagram

**Specifications and measurement uncertainty**

Specifications are established using 23 °C environmental temperature.

For measurement uncertainty improvements, the system can be readjusted at a specific environmental temperature to minimize the impact of temperature drift.

Any analog amplifier error source is a linear function ( $y = ax + b$ )

- a** % of reading error, represents the linear increasing error due to the increase of the input voltage: often referred to as gain error.
- b** % of range error, represents the error when measuring 0 V; often referred to as offset error.

For measurement uncertainty these errors can be considered independent error sources.

Noise is not a separate error source outside of the standard specification.

Noise specifications are added separately in case you need dynamic accuracy on sample by sample level.

Only for sample by sample measurement uncertainty add the RMS noise error.

For e.g. power accuracy, the RMS noise error is already included in the power specifications.

Pass/Fail limits are rectangular distributed specifications, therefore measurement uncertainty is 0.58 \* specified value.

**Adding/removing or swapping cards**

The specifications listed are valid for cards that have been calibrated and are used in the same mainframe, mainframe configuration and slots as they were at the time of calibration.

If cards are added, removed or relocated the thermal conditions of the card will change, resulting in additional thermal drift errors. The maximum expected error can be up to two times the specified Reading and Range error as well as 10 dB reduced common mode rejection.

Recalibration after configuration changes is therefore highly recommended.

## Power Wideband Pass/Fail Limits

0.33  $\Omega$  shunt:  $\pm 75$  mA,  $\pm 150$  mA,  $\pm 300$  mA,  $\pm 600$  mA and  $\pm 1.2$  A

	DC	1 Hz < f $\leq 25$ kHz	25 kHz < f $\leq 100$ kHz	100 kHz < f $\leq 200$ kHz	200 kHz < f $\leq 500$ kHz
Reading error DC and all power factors	0.015% <sup>(1)</sup>	0.015% + 0.04(fkHz)%	1.015%	0.015% + 0.01(fkHz)%	2.015% + 0.04(fkHz - 200kHz)%
Range error DC	0.02% + 2.5 mW <sup>(2)</sup>	--	--	--	--
Range error 0.5 < power factor $\leq 1$	--	0.02%	0.02%	0.02%	0.02%
Range error 0.01 $\leq$ power factor $\leq 0.5$	--	0.04%	0.04%	0.04%	0.04%

0.1  $\Omega$  shunt:  $\pm 1.0$  A and  $\pm 2.0$  A

	DC	1 Hz < f $\leq 25$ kHz	25 kHz < f $\leq 100$ kHz	100 kHz < f $\leq 200$ kHz	200 kHz < f $\leq 500$ kHz
Reading error DC and all power factors	0.02%	0.02 + 0.04(fkHz)%	1.02%	0.02 + 0.01(fkHz)%	2.02% + 0.04 (fkHz - 200kHz)%
Range error DC	0.04% + 2.5 mW	--	--	--	--
Range error 0.5 < power factor $\leq 1$	--	0.04%	0.04%	0.04%	0.04%

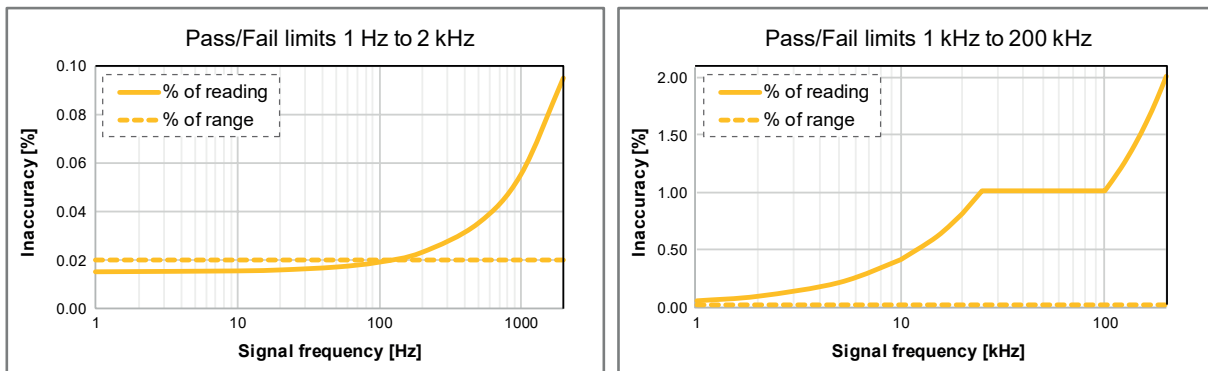
Figure 4: Power pass/fail limits (0.33  $\Omega$  shunt), Wideband and  $0.5 \leq$  Power Factor  $\leq 1$ 

- (1) For  $\pm 75$  mA range, the DC Reading error is 0.02%  
(2) For  $\pm 75$  mA range, the DC Range error is 0.04% + 2.5 mW

## Power Measurement Uncertainty Examples

For DC Power the power range is defined from 0 W to maximum DC voltage \* DC current.

For RMS power only when voltage and current sine waves are used without harmonic distortions, the maximum RMS power would be 0 to (Max DC voltage /  $\sqrt{2}$ ) \* (Max DC current /  $\sqrt{2}$ ). However, in real world applications these signals have large distortions, so maximum RMS power is harder to define.

Specification for both DC and RMS power therefore are all based on the power range calculated for DC signals. This creates a consistent spec, especially if both DC and RMS components exist in the same power signal to be measured.

As power calibration is a chain calibration, the individual voltage and current specifications can be excluded for power measurement uncertainty.

Comparing the same reading in two different power ranges		Power range	
400 W DC		600 W	1200 W
reading error	0.58 * 0.015% of reading	34.8 mW	34.8 mW
range error	0.58 * (0.02% of range + 2.5 mW)	71.05 mW	140.65 mW
Total error	$\sqrt{\text{reading error}^2 + \text{range error}^2}$	79.11 mW	144.89 mW
Uncertainty value (k=1)	total error / reading * 100%	<b>0.0198%</b>	<b>0.0362%</b>
250 W RMS at 10 kHz & power factor 1		600 W	1200 W
reading error	0.58 * (0.015 + (0.04 * f(kHz)))% of reading	602 mW	602 mW
range error	0.58 * 0.02% of range	69.6 mW	139.2 mW
Total error	$\sqrt{\text{reading error}^2 + \text{range error}^2}$	606.0 mW	617.9 mW
Uncertainty value (k=1)	total error / reading * 100%	<b>0.242%</b>	<b>0.247%</b>

**Power Pass/Fail Limit Overview: 0.33 Ω Shunt**

(Wideband and 0.5 < power factor <=1).  
 All values are calculated using the specifications of the Power Wideband Pass/Fail Limits. The listed value is the maximum inaccuracy that exist at the end of the frequency band. For more accurate values use the specified math in the table as listed in the Power Wideband Pass/Fail Limits.

Power ranges			Signal frequency (f)							
Voltage	Current	Power	DC	1 Hz < f ≤ 100 Hz	0.1 kHz < f ≤ 1 kHz	1 kHz < f ≤ 10 kHz	10 kHz < f ≤ 100 kHz	100 kHz < f ≤ 200 kHz	200 kHz < f ≤ 500 kHz	
± 1500 V DC [1060 V RMS]	± 1.2 A DC [0.84 A RMS]	1800 W	0.015% 0.020%	0.019% 0.020%	0.055% 0.020%	0.415% 0.020%	1.015% 0.020%	2.015% 0.020%	14.015% 0.020%	reading range
	± 0.6 A [0.42 A RMS]	900 W	0.015% 0.020%	0.019% 0.020%	0.055% 0.020%	0.415% 0.020%	1.015% 0.020%	2.015% 0.020%	14.015% 0.020%	reading range
	± 0.3 A [0.21 A RMS]	450 W	0.015% 0.021%	0.019% 0.020%	0.055% 0.020%	0.415% 0.020%	1.015% 0.020%	2.015% 0.020%	14.015% 0.020%	reading range
	± 0.15 A [0.10 A RMS]	225 W	0.015% 0.021%	0.019% 0.020%	0.055% 0.020%	0.415% 0.020%	1.015% 0.020%	2.015% 0.020%	14.015% 0.020%	reading range
	± 0.075 A [0.05 A RMS]	112.5 W	0.020% 0.041%	0.019% 0.020%	0.055% 0.020%	0.415% 0.020%	1.015% 0.020%	2.015% 0.020%	14.015% 0.020%	reading range
± 1000 V DC [700 V RMS]	± 1.2 A DC [0.84 A RMS]	1200 W	0.015% 0.020%	0.019% 0.020%	0.055% 0.020%	0.415% 0.020%	1.015% 0.020%	2.015% 0.020%	14.015% 0.020%	reading range
	± 0.6 A [0.42 A RMS]	600 W	0.015% 0.020%	0.019% 0.020%	0.055% 0.020%	0.415% 0.020%	1.015% 0.020%	2.015% 0.020%	14.015% 0.020%	reading range
	± 0.3 A [0.21 A RMS]	300 W	0.015% 0.021%	0.019% 0.020%	0.055% 0.020%	0.415% 0.020%	1.015% 0.020%	2.015% 0.020%	14.015% 0.020%	reading range
	± 0.15 A [0.10 A RMS]	150 W	0.015% 0.022%	0.019% 0.020%	0.055% 0.020%	0.415% 0.020%	1.015% 0.020%	2.015% 0.020%	14.015% 0.020%	reading range
	± 0.075 A [0.05 A RMS]	75 W	0.020% 0.043%	0.019% 0.020%	0.055% 0.020%	0.415% 0.020%	1.015% 0.020%	2.015% 0.020%	14.015% 0.020%	reading range
± 500 V DC [350 V RMS]	± 1.2 A DC [0.84 A RMS]	600 W	0.015% 0.020%	0.019% 0.020%	0.055% 0.020%	0.415% 0.020%	1.015% 0.020%	2.015% 0.020%	14.015% 0.020%	reading range
	± 0.6 A [0.42 A RMS]	300 W	0.015% 0.021%	0.019% 0.020%	0.055% 0.020%	0.415% 0.020%	1.015% 0.020%	2.015% 0.020%	14.015% 0.020%	reading range
	± 0.3 A [0.21 A RMS]	150 W	0.015% 0.022%	0.019% 0.020%	0.055% 0.020%	0.415% 0.020%	1.015% 0.020%	2.015% 0.020%	14.015% 0.020%	reading range
	± 0.15 A [0.10 A RMS]	75 W	0.015% 0.023%	0.019% 0.020%	0.055% 0.020%	0.415% 0.020%	1.015% 0.020%	2.015% 0.020%	14.015% 0.020%	reading range
	± 0.075 A [0.05 A RMS]	37.5 W	0.020% 0.047%	0.019% 0.020%	0.055% 0.020%	0.415% 0.020%	1.015% 0.020%	2.015% 0.020%	14.015% 0.020%	reading range
± 100 V DC [70 V RMS]	± 1.2 A DC [0.84 A RMS]	120 W	0.015% 0.022%	0.019% 0.020%	0.055% 0.020%	0.415% 0.020%	1.015% 0.020%	2.015% 0.020%	14.015% 0.020%	reading range
	± 0.6 A [0.42 A RMS]	60 W	0.015% 0.024%	0.019% 0.020%	0.055% 0.020%	0.415% 0.020%	1.015% 0.020%	2.015% 0.020%	14.015% 0.020%	reading range
	± 0.3 A [0.21 A RMS]	30 W	0.015% 0.028%	0.019% 0.020%	0.055% 0.020%	0.415% 0.020%	1.015% 0.020%	2.015% 0.020%	14.015% 0.020%	reading range
	± 0.15 A [0.10 A RMS]	15 W	0.015% 0.037%	0.019% 0.020%	0.055% 0.020%	0.415% 0.020%	1.015% 0.020%	2.015% 0.020%	14.015% 0.020%	reading range
	± 0.075 A [0.05 A RMS]	7.5 W	0.020% 0.073%	0.019% 0.020%	0.055% 0.020%	0.415% 0.020%	1.015% 0.020%	2.015% 0.020%	14.015% 0.020%	reading range
± 50 V DC [35 V RMS]	± 1.2 A DC [0.84 A RMS]	60 W	0.015% 0.024%	0.019% 0.020%	0.055% 0.020%	0.415% 0.020%	1.015% 0.020%	2.015% 0.020%	14.015% 0.020%	reading range
	± 0.6 A [0.42 A RMS]	30 W	0.015% 0.028%	0.019% 0.020%	0.055% 0.020%	0.415% 0.020%	1.015% 0.020%	2.015% 0.020%	14.015% 0.020%	reading range
	± 0.3 A [0.21 A RMS]	15 W	0.015% 0.037%	0.019% 0.020%	0.055% 0.020%	0.415% 0.020%	1.015% 0.020%	2.015% 0.020%	14.015% 0.020%	reading range
	± 0.15 A [0.10 A RMS]	7.5 W	0.015% 0.053%	0.019% 0.020%	0.055% 0.020%	0.415% 0.020%	1.015% 0.020%	2.015% 0.020%	14.015% 0.020%	reading range
	± 0.075 A [0.05 A RMS]	3.75 W	0.020% 0.107%	0.019% 0.020%	0.055% 0.020%	0.415% 0.020%	1.015% 0.020%	2.015% 0.020%	14.015% 0.020%	reading range

Power Pass/Fail Limit Overview: 0.1  $\Omega$  Shunt

(Wideband and  $0.5 < \text{power factor} \leq 1$ ).

All values are calculated using the specifications of the Power Wideband Pass/Fail Limits. The listed value is the maximum inaccuracy that exist at the end of the frequency band. For more accurate values use the specified math in the table as listed in the Power Wideband Pass/Fail Limits.

Power ranges			Signal frequency (f)							
Voltage	Current	Power	DC	1 Hz < f $\leq$ 100 Hz	0.1 kHz < f $\leq$ 1 kHz	1 kHz < f $\leq$ 10 kHz	10 kHz < f $\leq$ 100 kHz	100 kHz < f $\leq$ 200 kHz	200 kHz < f $\leq$ 500 kHz	
$\pm$ 1500 V DC [1060 V RMS]	$\pm$ 2.0 A [1.40 A RMS]	3000 W	0.020% 0.040%	0.020% 0.040%	0.060% 0.040%	0.420% 0.040%	1.020% 0.040%	2.020% 0.040%	14.020% 0.040%	reading range
	$\pm$ 1.0 A [0.70 A RMS]	1500 W	0.020% 0.040%	0.020% 0.040%	0.060% 0.040%	0.420% 0.040%	1.020% 0.040%	2.020% 0.040%	14.020% 0.040%	reading range
$\pm$ 1000 V DC [700 V RMS]	$\pm$ 2.0 A [1.40 A RMS]	2000 W	0.020% 0.040%	0.020% 0.040%	0.060% 0.040%	0.420% 0.040%	1.020% 0.040%	2.020% 0.040%	14.020% 0.040%	reading range
	$\pm$ 1.0 A [0.70 A RMS]	1000 W	0.020% 0.040%	0.020% 0.040%	0.060% 0.040%	0.420% 0.040%	1.020% 0.040%	2.020% 0.040%	14.020% 0.040%	reading range
$\pm$ 500 V DC [350 V RMS]	$\pm$ 2.0 A [1.40 A RMS]	1000 W	0.020% 0.040%	0.020% 0.040%	0.060% 0.040%	0.420% 0.040%	1.020% 0.040%	2.020% 0.040%	14.020% 0.040%	reading range
	$\pm$ 1.0 A [0.70 A RMS]	500 W	0.020% 0.041%	0.020% 0.040%	0.060% 0.040%	0.420% 0.040%	1.020% 0.040%	2.020% 0.040%	14.020% 0.040%	reading range
$\pm$ 100 V DC [70 V RMS]	$\pm$ 2.0 A [1.40 A RMS]	200 W	0.020% 0.041%	0.020% 0.040%	0.060% 0.040%	0.420% 0.040%	1.020% 0.040%	2.020% 0.040%	14.020% 0.040%	reading range
	$\pm$ 1.0 A [0.70 A RMS]	100 W	0.020% 0.043%	0.020% 0.040%	0.060% 0.040%	0.420% 0.040%	1.020% 0.040%	2.020% 0.040%	14.020% 0.040%	reading range
$\pm$ 50 V DC [35 V RMS]	$\pm$ 2.0 A [1.40 A RMS]	100 W	0.020% 0.043%	0.020% 0.040%	0.060% 0.040%	0.420% 0.040%	1.020% 0.040%	2.020% 0.040%	14.020% 0.040%	reading range
	$\pm$ 1.0 A [0.70 A RMS]	50 W	0.020% 0.045%	0.020% 0.040%	0.060% 0.040%	0.420% 0.040%	1.020% 0.040%	2.020% 0.040%	14.020% 0.040%	reading range

Voltage Channels	
Channels	3 high voltage
Connectors	Fully isolated 4 mm banana plugs (plastic), 2 per channel (red and black)
Input type	Analog, isolated, balanced differential
Input impedance	5 MΩ ± 1% // 4 pF ± 20%
Input coupling modes	DC, GND
Ranges	± 50 V, ± 100 V, ± 500 V, ± 1000 V and ± 1500 V
Offset	± 50% in 1000 steps (0.1%) ± 1000 V range, ± 25% offset ± 1500 V range has fixed 0% offset
CAT rating	
Differential input	1500 V DC CAT III, 1000 V CAT IV
Input to chassis	1000 V CAT III, 600 V CAT IV
Common mode (referred to system ground)	
Rejection (CMR)	> 60 dB @ 80 Hz (80 dB typical)
Maximum common mode voltage	1000 V RMS
<p>The graph, titled 'Common mode response', plots Magnitude [%] on the left y-axis (log scale from 0.001 to 100) and Magnitude [dB] on the right y-axis (linear scale from -100 to 0) against Frequency [kHz] on the x-axis (log scale from 0.01 to 1000). A single yellow line represents 'All ranges'. The magnitude is constant at 0.1% (approx -60 dB) from 0.01 kHz to 0.1 kHz. Between 0.1 kHz and 10 kHz, the magnitude increases linearly on the log-log scale, reaching 10% (approx -20 dB) at 10 kHz. From 10 kHz to 1000 kHz, the magnitude remains constant at 10% (approx -20 dB).</p>	
<b>Figure 5: Common mode response (Voltage Channels)</b>	
Maximum nondestructive differential input voltage	2000 V RMS
Overload recovery time	Restored to 0.1% accuracy in less than 5 μs after 200% overload

**Voltage Specifications (Wideband) - DC**

	Pass/Fail limits
DC Reading error	0.01% of reading
DC Range error	0.01% of range $\pm$ 10 mV
DC Reading error drift	$\pm$ 25.0 ppm/ $^{\circ}$ C ( $\pm$ 14 ppm/ $^{\circ}$ F)
DC Range error drift	$\pm$ 30.0 ppm/ $^{\circ}$ C ( $\pm$ 17 ppm/ $^{\circ}$ F)
RMS Noise (50 $\Omega$ terminated)	0.005% of range $\pm$ 10 mV

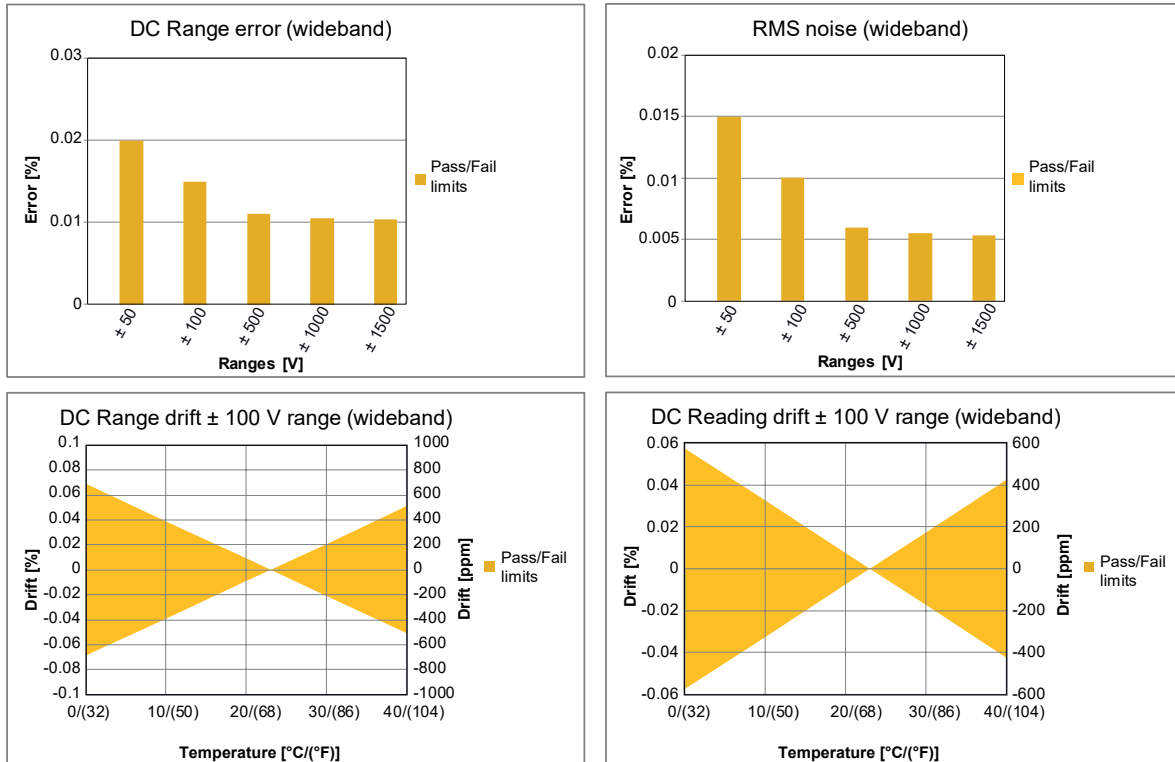

Figure 6: Wideband voltage specification

**Voltage Specifications (Wideband) - AC**

All values are calculated using the voltage channels inaccuracy specifications. The listed value is the maximum inaccuracy that exist at the end of the frequency band. For more accurate values use the specified math in the voltage channels inaccuracy specification table.

Voltage range	Signal frequency (f)						
	1 Hz < f $\leq$ 100 Hz	100 Hz < f $\leq$ 1 kHz	1 kHz < f $\leq$ 20 kHz	20 kHz < f $\leq$ 100 kHz	100 kHz < f $\leq$ 200 kHz	200 kHz < f $\leq$ 500 kHz	
All ranges ( $\pm$ 50 V, $\pm$ 100 V, $\pm$ 500 V, $\pm$ 1000 V, $\pm$ 1500 V)	0.010%	0.025%	max 0.806%; (0.025 + 0.6*log(fkHz)) %	max 1.225%; (0.025 + 0.6*log(fkHz)) %	max 3.225%; (0.020*(fkHz) - 0.775) %	max 9.225%; (0.020*(fkHz) - 0.775) %	reading
	0.010%	0.010%	0.010%	0.010%	0.010%	0.010%	range

Voltage Specifications (All Filters Used) - DC

	Pass/Fail limits
DC Reading error	0.01% of reading
DC Range error	0.01% of range $\pm$ 1 mV
DC Reading error drift	$\pm$ 20.0 ppm/ $^{\circ}$ C ( $\pm$ 11 ppm/ $^{\circ}$ F)
DC Range error drift	$\pm$ 40.0 ppm/ $^{\circ}$ C ( $\pm$ 22 ppm/ $^{\circ}$ F)
RMS Noise (50 $\Omega$ terminated)	0.008% of range $\pm$ 5 mV

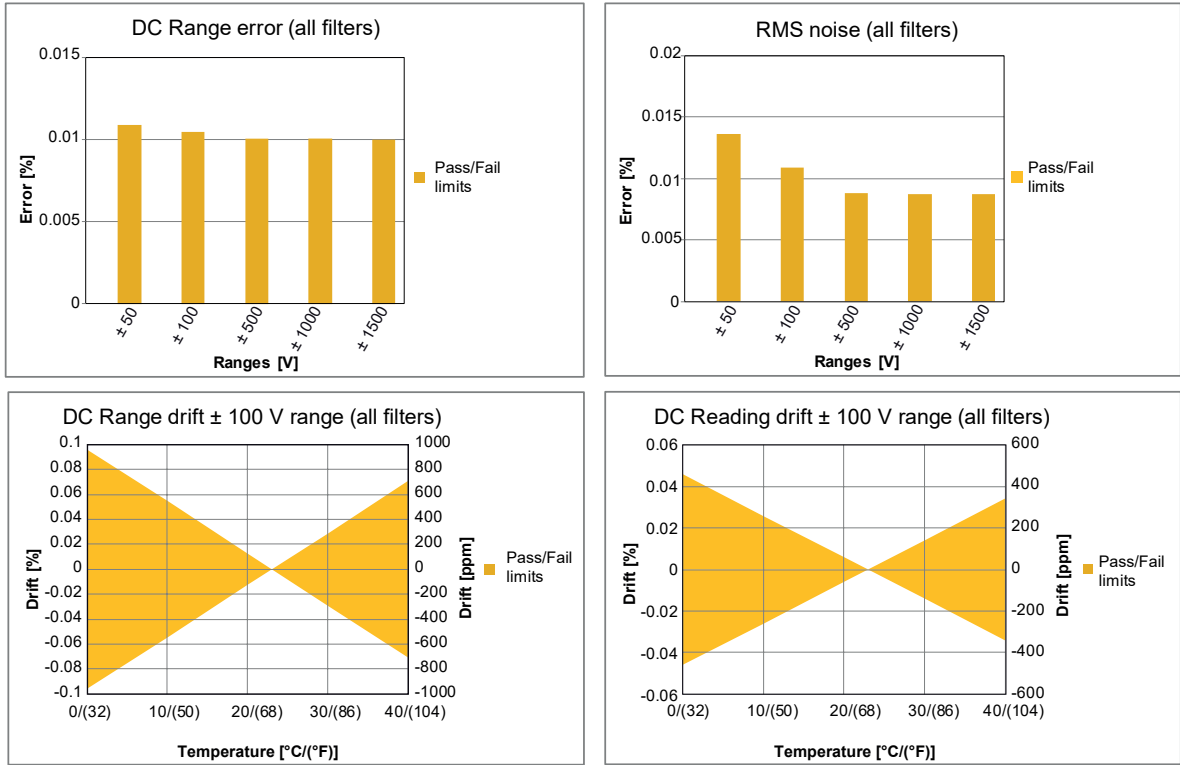
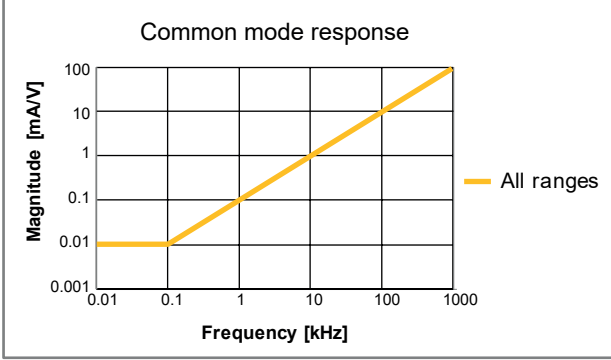

Figure 7: All filters used voltage specification

Current Channels: Current Mode	
Channels	3 current
Connectors	LEMO connector, 1 per channel
Input type	Analog, isolated, unbalanced differential
Input impedance	< 0.6 $\Omega$ (shunt resistor plus protection)
Input coupling modes	DC, GND (current path stays closed)
Ranges	$\pm 0.075$ A, $\pm 0.15$ A, $\pm 0.3$ A, $\pm 0.6$ A, $\pm 1.0$ A, $\pm 1.2$ A, $\pm 2.0$ A
Offset	0% offset (no offset correction)
Built-in shunt resistors	0.33 $\Omega$ , 5 ppm/ $^{\circ}$ C ( $\pm 0.075$ A, $\pm 0.15$ A, $\pm 0.3$ A, $\pm 0.6$ A, $\pm 1.2$ A) 0.1 $\Omega$ , 20 ppm/ $^{\circ}$ C ( $\pm 1.0$ A, $\pm 2.0$ A)
Common mode (referred to system ground)	
Rejection (CMR)	< 10 $\mu$ A/V @ 80 Hz
Maximum common mode voltage	30 V RMS
	
<b>Figure 8:</b> Common mode response (Current Channels: Current Mode)	
Maximum nondestructive current	$\pm 2.5$ A DC Internally protected with resettable PTC fuses. <b>Note:</b> PTC fuses, when tripped, need time to cool down to meet the input impedance specification.
Isolation voltage	60 V DC

**Current Channels: Current Mode Specifications (Wideband) - DC**

	Pass/Fail limits
DC Reading error	0.05% of reading
DC Range error	0.005% of range $\pm$ 200 $\mu$ A
DC Reading error drift	0.33 $\Omega$ shunt resistor: $\pm$ 25 ppm/ $^{\circ}$ C ( $\pm$ 14 ppm/ $^{\circ}$ F) 0.1 $\Omega$ shunt resistor: $\pm$ 110 ppm/ $^{\circ}$ C ( $\pm$ 61 ppm/ $^{\circ}$ F)
DC Range error drift	$\pm$ (20 ppm + 15 $\mu$ A)/ $^{\circ}$ C ( $\pm$ (11 ppm + 8 $\mu$ A)/ $^{\circ}$ F)
RMS Noise (50 $\Omega$ terminated)	0.007% of range $\pm$ 100 $\mu$ A

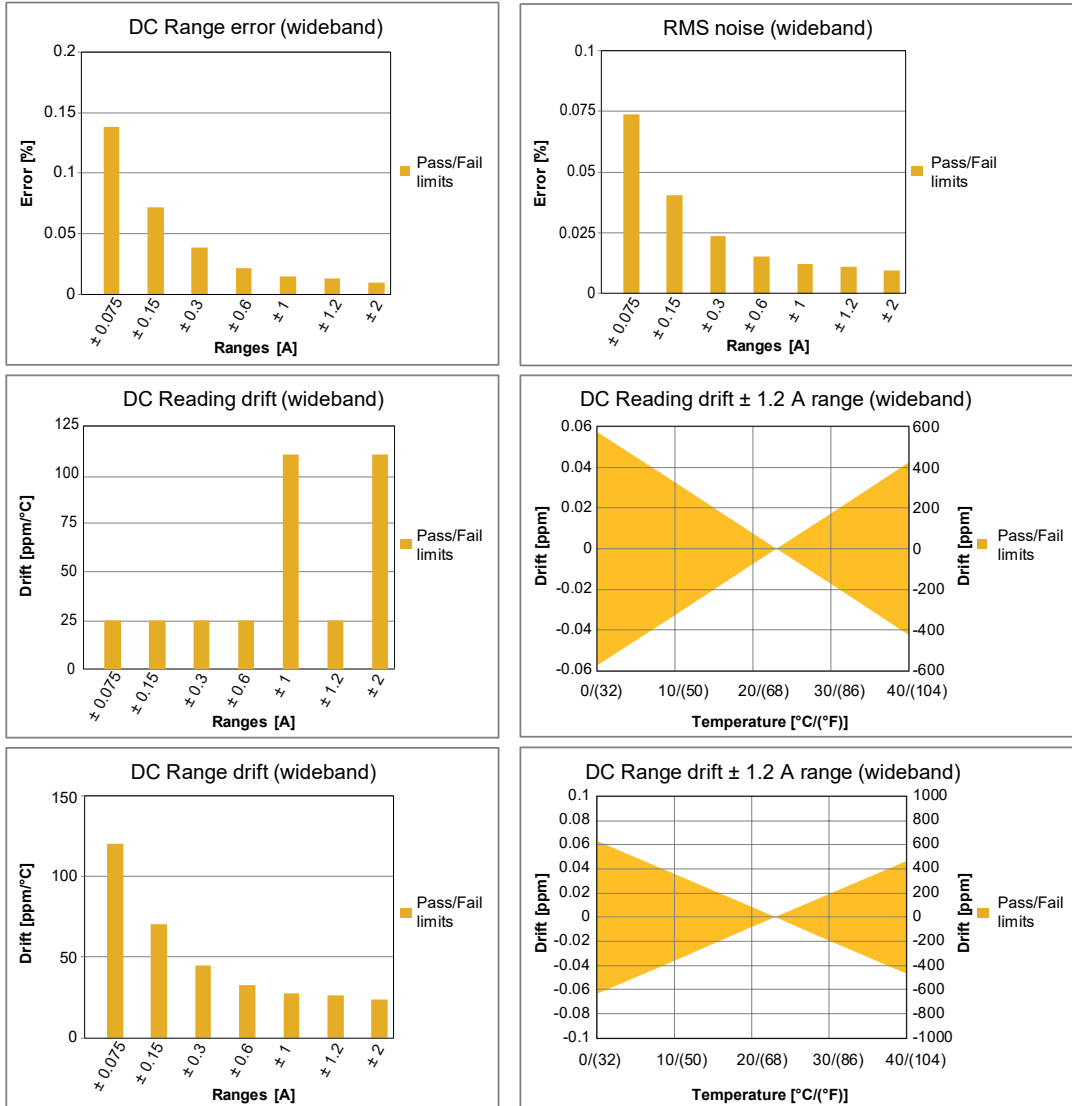

Figure 9: Wideband current mode specification

**Current Channels: Current Mode Specifications (All Filters Used) - DC**

	Pass/Fail limits
DC Reading error	0.05% of reading
DC Range error	0.005% of range $\pm 50 \mu\text{A}$
DC Reading error drift	0.33 $\Omega$ shunt resistor: $\pm 25 \text{ ppm}/^\circ\text{C}$ ( $\pm 14 \text{ ppm}/^\circ\text{F}$ ) 0.1 $\Omega$ shunt resistor: $\pm 110 \text{ ppm}/^\circ\text{C}$ ( $\pm 61 \text{ ppm}/^\circ\text{F}$ )
DC Range error drift	$\pm (30 \text{ ppm} + 15 \mu\text{A})/^\circ\text{C}$ ( $\pm (17 \text{ ppm} + 8 \mu\text{A})/^\circ\text{F}$ )
RMS Noise (50 $\Omega$ terminated)	0.005% of range $\pm 50 \mu\text{A}$

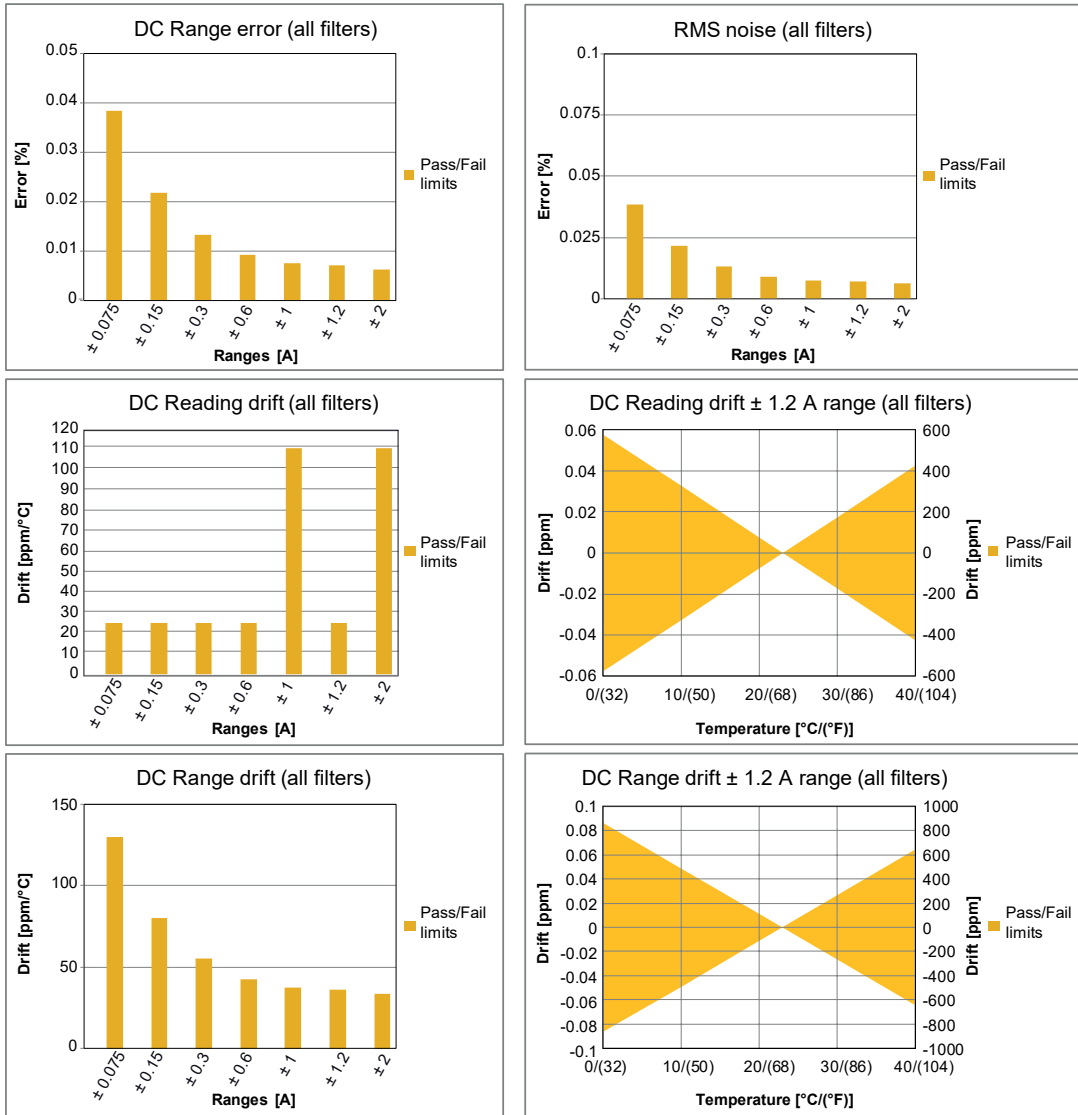

Figure 10: All filters used current mode specification

## Current channels, Current mode Pass/Fail Limits Overview - AC

All values are calculated using the current channels, current mode inaccuracy specifications. The listed value is the maximum inaccuracy that exist at the end of the frequency band. For more accurate values use the specified math in the current channels, current mode inaccuracy specification table.

Shunt resistor	Signal frequency (f)			
	1 Hz < f ≤ 100 Hz	100 Hz < f ≤ 1 kHz	1 kHz < f ≤ 10 kHz	
Pass/Fail limit at 0.33 Ω				
0.33 Ω shunt <sup>(1)</sup>	0.010% const.	max 0,21%	max 0,41%	reading
		(0.21 + 0.2*log(fkhz)) %		
	0.010%	0.010%	0.010%	range
Pass/Fail limit at 0.1 Ω				
0.1 Ω shunt <sup>(2)</sup>	0.010% const.	max 0,31%	max 0,61%	reading
		(0.31 + 0.3*log(fkhz)) %		
	0.020%	0.020%	0.020%	range

(1) ±75 mA, ±150 mA, ±300 mA, ± 0.6 A and ± 1.2 A

(2) ± 1.0 A and ± 2.0 A

Current Channel: Voltage Mode		
Channels	3 voltage	
Connectors	LEMO connector, 1 per channel	
Input type	Analog, isolated, unbalanced differential	
Input impedance	1 M $\Omega$ $\pm$ 1% // 40 pF $\pm$ 10%	
Input coupling modes	DC, GND	
Ranges	$\pm$ 50 mV, $\pm$ 100 mV, $\pm$ 200 mV, $\pm$ 500 mV, $\pm$ 1 V, $\pm$ 2 V, $\pm$ 5 V, $\pm$ 10 V, $\pm$ 20 V	
Offset	$\pm$ 50% in 1000 steps (0.1%) $\pm$ 20 V range has fixed 0% offset	
Common mode (referred to system ground)		
Ranges	Less than $\pm$ 5 V	Larger than or equal to $\pm$ 5 V
Rejection (CMR)	> 80 dB @ 80 Hz (100 dB typical)	> 60 dB @ 80 Hz (80 dB typical)
Maximum common mode voltage	30 V RMS	
<b>Figure 11: Common mode response (Current Channels: Voltage Mode)</b>		
Overvoltage impedance change	The activation of the overvoltage protection system results in a reduced input impedance. The overvoltage protection is not active as long as the input voltage remains less than 200% of the selected input range.	
Maximum nondestructive current	$\pm$ 35 V DC	
Isolation voltage	60 V DC	
Overload recovery time	Restored to 0.1% accuracy in less than 5 $\mu$ s after 200% overload	

Current Channels: Voltage Mode Specifications (Wideband) - DC

	Pass/Fail limits
DC Reading error	0.02% of reading $\pm$ 100 $\mu$ V
DC Range error	0.002% of range $\pm$ 750 $\mu$ V
DC Reading error drift	$\pm$ 25 ppm/ $^{\circ}$ C ( $\pm$ 14 ppm/ $^{\circ}$ F)
DC Range error drift	$\pm$ (10 ppm + 5 $\mu$ V)/ $^{\circ}$ C ( $\pm$ (6 ppm + 3 $\mu$ V)/ $^{\circ}$ F)
RMS Noise (50 $\Omega$ terminated)	0.007% of range $\pm$ 100 $\mu$ V

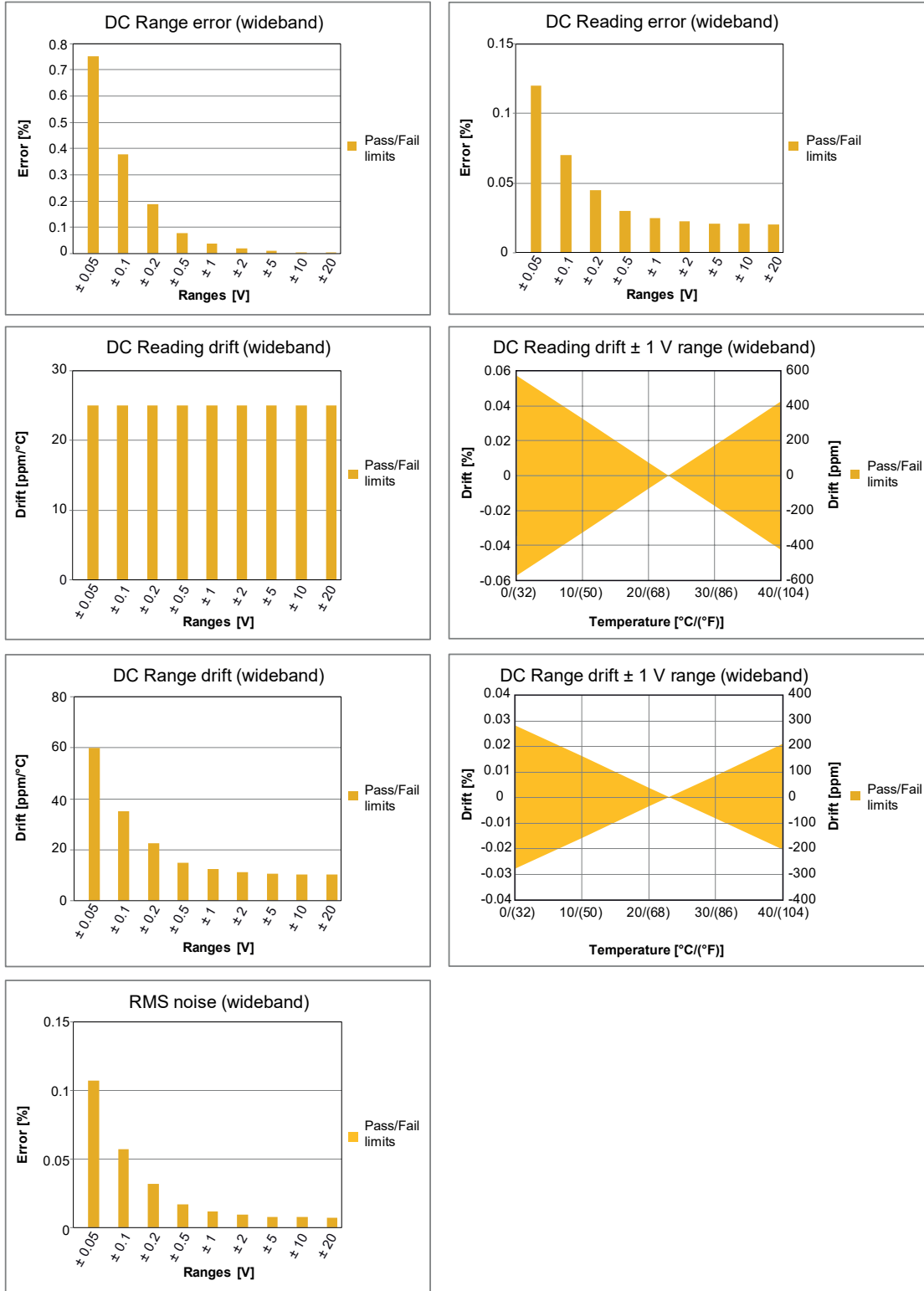

Figure 12: Wideband voltage mode specification

Current Channels: Voltage Mode Specifications (All Filters Used) - DC

	Pass/Fail limits
DC Reading error	0.02% of reading $\pm$ 100 $\mu$ V
DC Range error	0.005 % of range $\pm$ 50 $\mu$ V
DC Reading error drift	$\pm$ 25 ppm/ $^{\circ}$ C ( $\pm$ 14 ppm/ $^{\circ}$ F)
DC Range error drift	$\pm$ (30 ppm + 5 $\mu$ V)/ $^{\circ}$ C ( $\pm$ (17 ppm + 3 $\mu$ V)/ $^{\circ}$ F)
RMS Noise (50 $\Omega$ terminated)	0.005% of range $\pm$ 20 $\mu$ V

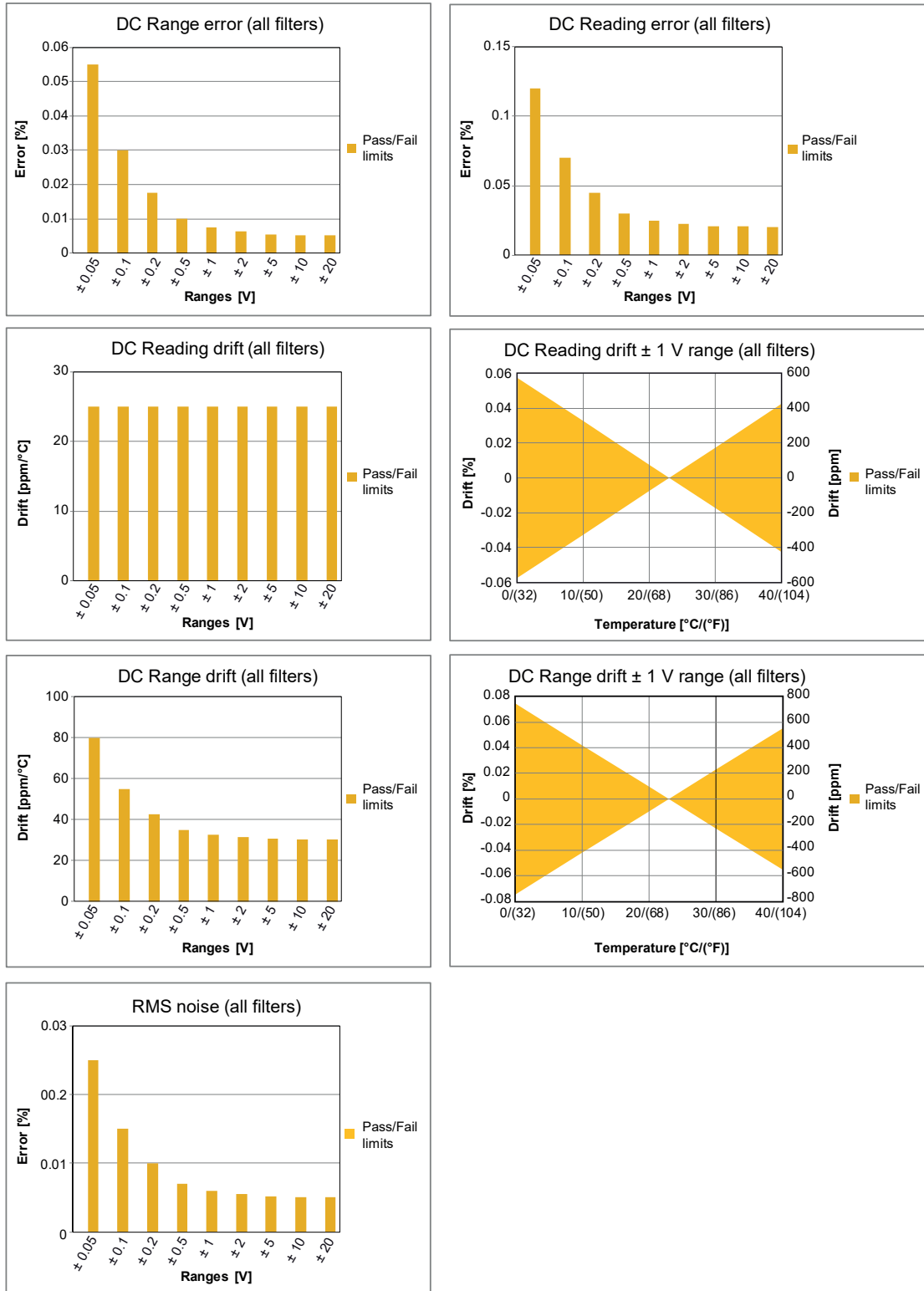

Figure 13: All filters used voltage mode specification

## Current channels, Voltage mode Pass/Fail Limits Overview - AC

All values are calculated using the current channels, voltage mode inaccuracy specifications. The listed value is the maximum inaccuracy that exist at the end of the frequency band. For more accurate values use the specified math in the current channels, voltage mode inaccuracy specification table.

	1 Hz < f ≤ 1 kHz	1 kHz < f ≤ 10 kHz	1 kHz < f ≤ 20 kHz	20 kHz < f ≤ 100 kHz	100 kHz < f ≤ 200 kHz	200 kHz < f ≤ 500 kHz	
± 0.05 V DC [35 mV RMS]	0.010% const		0.070%	0.550%	2.550%	8.550%	reading
			(0.006*(fkHz) - 0.05)%		(0.02*(fkHz) - 1.45)%		
	0.060%						range
± 0.1 V DC [70 mV RMS]	0.010% const		0.070%	0.550%	2.550%	8.550%	reading
			(0.006*(fkHz) - 0.05)%		(0.02*(fkHz) - 1.45)%		
	0.030%						range
± 0.2 V DC [140 mV RMS]	0.010% const		0.070%	0.550%	2.550%	8.550%	reading
			(0.006*(fkHz) - 0.05)%		(0.02*(fkHz) - 1.45)%		
	0.015%						range
± 0.5 V ≤ Range < ± 5 V	0.010% const		0.070%	0.550%	2.350%	7.750%	reading
			(0.006*(fkHz) - 0.05)%		(0.02*(fkHz) - 1.45)%		
	0.010%						range
Range ≥ ± 5 V	0.010% const	0.410%	0.530%	0.810%	2.610%	8.010%	reading
		(0.01 + 0.4*log(fkHz))%			(0.018*(fkHz) - 0.99)%		
	0.010%						range

## GN310B/GN311B Current Connector and Pinings

GN310B/GN311B front panel connector	LEMO EPG.1B.304.HLN
Mating connector	LEMO FGG.1B.304.CLAD52 (Check cable collet selection)*

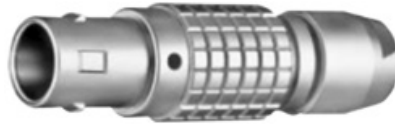

Figure 14: FGG.1B.304.CLAD52 mating LEMO connector

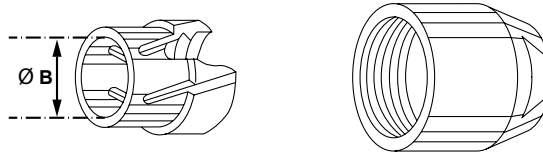

Figure 15: Cable collet setup

* Cable collet selection:	Minimum cable diameter ØB	Maximum cable diameter ØB
M27	2.2 mm	2.7 mm
M31	2.7 mm	3.1 mm
D42	3.1 mm	4.2 mm
D52	4.2 mm	5.2 mm
D62	5.2 mm	6.2 mm
D72	6.2 mm	7.2 mm
D76	7.2 mm	7.6 mm

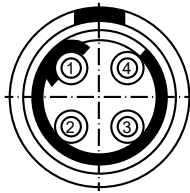

Figure 16: Cable connector soldering view

Signal name (Cable/Connector color)	Pin number
Current input (White/Blue)	1
Voltage input (Brown/Red)	2
Ground/shield (Yellow/Yellow)	3
Input return/Isolated ground (Green/Black)	4

Voltage Channels Isolation IEC 61010-2-030:2017

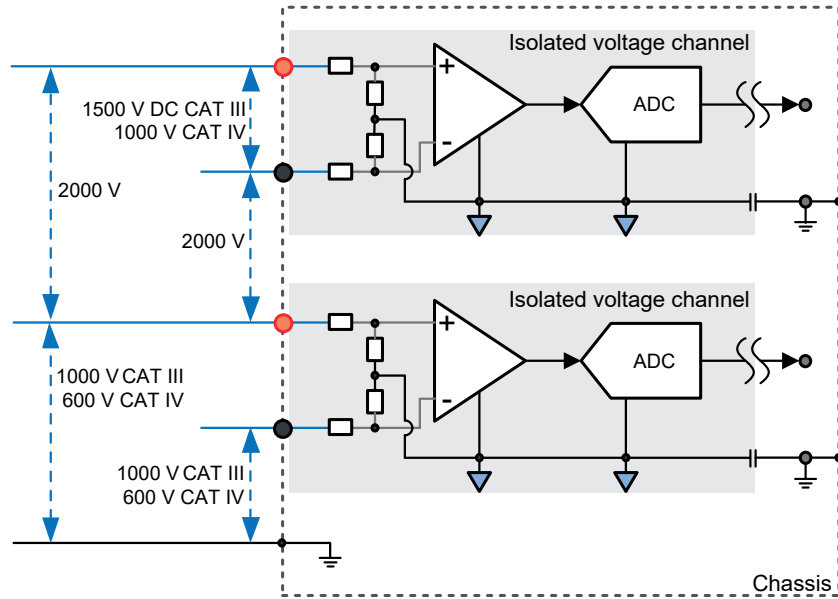

Figure 17: Voltage channels isolation ratings

Positive input pin to negative input pin	1500 V DC CAT III, 1000 V CAT IV
Input pin to chassis	1000 V CAT III, 600 V CAT IV
Channel to channel	2000 V RMS

Current Channels Isolation IEC 61010-2-030:2017

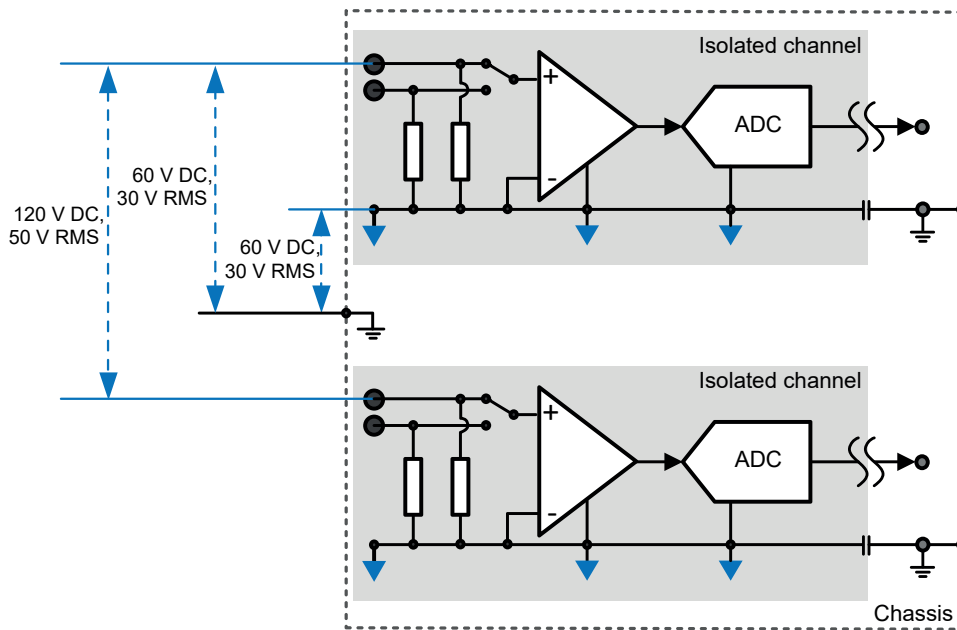

Figure 18: Current channels isolation ratings

Input pin to chassis	± 60 V DC, 30 V RMS
Channel to channel	120 V DC, 50 V RMS

## Isolation and Input Type Testing (Voltage Channel)

### IEC 61010-1 and IEC 61010-2-030 isolation tests

Channel to channel	7400 V RMS for 5 s 4400 V RMS for 60 s
Channel to chassis	7400 V RMS for 5 s 4400 V RMS for 60 s
Differential	8250 V RMS for 5 s 2200 V RMS 60 s 3200 V DC for 60 s
Differential impulse	12 kV peak using a 2 $\Omega$ series resistor Rise time 1.2 $\mu$ s, 50% amplitude reduction in 50 $\mu$ s
Channel to channel impulse	7 kV peak using a 2 $\Omega$ series resistor Rise time 1.2 $\mu$ s, 50% amplitude reduction in 50 $\mu$ s
Channel to chassis impulse	8 kV peak using a 2 $\Omega$ series resistor Rise time 1.2 $\mu$ s, 50% amplitude reduction in 50 $\mu$ s

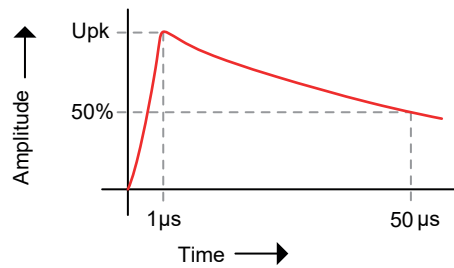

Figure 19: Example of 1.2/50  $\mu$ s impulse

**Analog to Digital Conversion**

Sample rate; per channel	0.1 S/s to 2 MS/s (GN310B) or 0.1 S/s to 200 kS/s (GN311B)
ADC resolution; one ADC per channel	18 bit
ADC type	Successive Approximation Register (SAR); Analog Devices AD4003BCPZ
Time base accuracy	Defined by mainframe: ± 3.5 ppm; aging after 10 years ± 10 ppm

**Anti-Alias Filters**

Note on phase matching channels. Every filter characteristic and/or filter bandwidth selection comes with its own specific phase response. Using different filter selections (Wideband/Bessel/Butterworth/Bessel IIR/Butterworth IIR/Elliptic IIR) or different filter bandwidths can result in phase mismatches between channels.

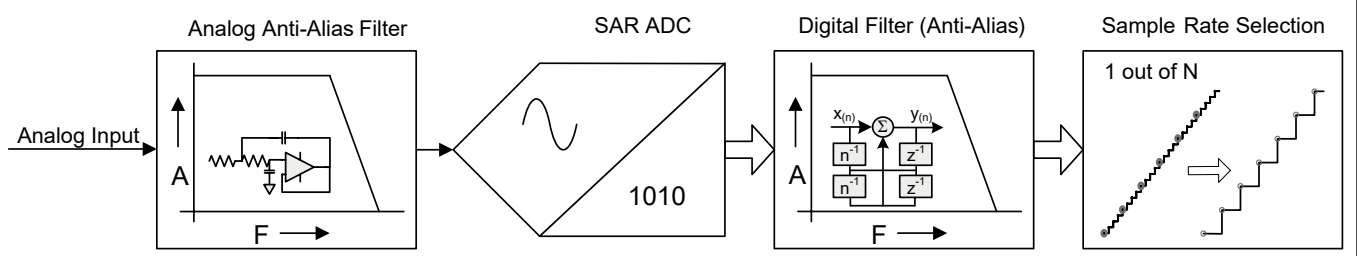

Figure 20: Combined analog and digital anti-alias filter block diagram

Anti-aliasing is prevented by a steep, fixed frequency analog anti-alias filter in front of the Analog to Digital Converter (ADC). The ADC always samples at a fixed sample rate. The fixed sample rate of the ADC avoids the need for different analog anti-alias filter frequencies. Directly behind the ADC, the high precision digital filter is used as anti-alias protection before the digital downsampling to the desired user sample rate is performed. The digital filter is programmed to a fraction of the user sample rate and automatically tracks any user sample rate selection. Compared to analog anti-alias filters, the programmable digital filter offers additional benefits like higher order filter with steep roll-off, a larger selection of filter characteristics, noise-free digital output and no additional phase shifts between channels that use the same filter settings.

Wideband <sup>(1)</sup>	When wideband is selected, there is neither an analog anti-alias filter nor any digital filter in the signal path. Therefore, there is no anti-alias protection when wideband is selected. Wideband should not be used if working in a frequency domain with recorded data.
Bessel (Fc @ -3 dB) <sup>(1)</sup>	This analog Bessel filter can be used to reduce the higher bandwidth signals, especially at maximum sample rate 2 MS/s or 200 kS/s. For lower sample rates, the digital IIR filter is a better choice to prevent aliasing. Bessel filters are typically used when looking at signals in the time domain. They are best used for measuring transient signals or sharp edge signals like square waves or step responses.
Butterworth (Fc @ -3 dB) <sup>(1)</sup>	This analog Butterworth filter can be used to reduce the higher bandwidth signals, especially at maximum sample rate 2 MS/s or 200 kS/s. For lower sample rates, the digital IIR filter is a better choice to prevent aliasing. Butterworth filters are typically used when looking at (near) sine wave signals in the time domain or signals in the frequency domain.
Bessel IIR (Fc @ -3 dB)	When Bessel IIR filter is selected, this is always a combination of an analog Bessel anti-alias filter and a digital Bessel IIR filter to prevent aliasing at lower sample rates. Bessel filters are typically used when looking at signals in the time domain. They are best used for measuring transient signals or sharp edge signals like square waves or step responses.
Butterworth IIR (Fc @ -3 dB)	When Butterworth IIR filter is selected, this is always a combination of an analog Bessel anti-alias filter and a digital Butterworth IIR filter to prevent aliasing at lower sample rates. This filter is best used when working in the frequency domain. When working in the time domain, this filter is best used for signals that are (close to) sine waves.
Elliptic IIR (Fc @ -0.1 dB)	When Elliptic IIR filter is selected, this is always a combination of an analog Butterworth anti-alias filter and a digital Elliptic IIR filter to prevent aliasing at lower sample rates. This filter is best used when working in the frequency domain. When working in the time domain, this filter is best used for signals that are (close to) sine waves.

(1) Wideband and analog Anti-Alias filters are valid for GN310B only.

## Bandwidth and Filter Characteristic Selection versus Sample Rate

The digital filter before decimation guarantees a superior phase match, ultra-low noise and alias free result.

	Wideband	Digital lowpass filters (alias free by using an analog anti alias filter in front of ADC)				
	No Anti-alias filter	Butterworth IIR Elliptic IIR	Bessel IIR Butterworth IIR Elliptic IIR	Bessel IIR Butterworth IIR Elliptic IIR	Bessel IIR Butterworth IIR Elliptic IIR	Bessel IIR
User selectable sample rates		1/4 Fs	1/10 Fs	1/20 Fs	1/40 Fs	1/100 Fs
2 MS/s	Wideband	--	200 kHz	100 kHz	50 kHz	20 kHz
1 MS/s	Wideband	250 kHz	100 kHz	50 kHz	25 kHz	10 kHz
500 kS/s	Wideband	125 kHz	50 kHz	25 kHz	12.5 kHz	5 kHz
400 kS/s	Wideband	100 kHz	40 kHz	20 kHz	10 kHz	4 kHz
250 kS/s	Wideband	62.5 kHz	25 kHz	12.5 kHz	6.25 kHz	2.5 kHz
200 kS/s	Wideband	50 kHz	20 kHz	10 kHz	5 kHz	2 kHz
125 kS/s	Wideband	25 kHz	12.5 kHz	6.25 kHz	2.5 kHz	1.25 kHz
100 kS/s	Wideband	20 kHz	10 kHz	5 kHz	2 kHz	1 kHz
50 kS/s	Wideband	12.5 kHz	5 kHz	2.5 kHz	1.25 kHz	500 Hz
40 kS/s	Wideband	10 kHz	4 kHz	2 kHz	1 kHz	400 Hz
25 kS/s	Wideband	6.25 kHz	2.5 kHz	1.25 kHz	625 Hz	250 Hz
20 kS/s	Wideband	5 kHz	2 kHz	1 kHz	500 Hz	200 Hz
12.5 kS/s	Wideband	2.5 kHz	1.25 kHz	625 Hz	312.5 Hz	125 Hz
10 kS/s	Wideband	2 kHz	1 kHz	500 Hz	250 Hz	100 Hz
5 kS/s	Wideband	1.25 kHz	500 Hz	250 Hz	125 Hz	50 Hz
4 kS/s	Wideband	1 kHz	400 Hz	200 Hz	100 Hz	40 Hz
2.5 kS/s	Wideband	625 Hz	250 Hz	125 Hz	62.5 Hz	25 Hz
2 kS/s	Wideband	500 Hz	200 Hz	100 Hz	50 Hz	20 Hz
1.25 kS/s	Wideband	312.5 Hz	125 Hz	62.5 Hz	31.25 Hz	12.5 Hz
1 kS/s	Wideband	250 Hz	100 Hz	50 Hz	25 Hz	10 Hz
500 S/s	Wideband	125 Hz	50 Hz	25 Hz	12.5 Hz	5 Hz
400 S/s	Wideband	100 Hz	40 Hz	20 Hz	10 Hz	4 Hz
250 S/s	Wideband	62.5 Hz	25 Hz	12.5 Hz	6.25 Hz	2.5 Hz
200 S/s	Wideband	50 Hz	20 Hz	10 Hz	5 Hz	2 Hz
125 S/s	Wideband	31.25 Hz	12.5 Hz	6.25 Hz	3.125 Hz	1.25 Hz
100 S/s	Wideband	25 Hz	10 Hz	5 Hz	2.5 Hz	1 Hz
50 S/s	Wideband	12.5 Hz	5 Hz	2.5 Hz	1.25 Hz	0.5 Hz
40 S/s	Wideband	10 Hz	4 Hz	2 Hz	1 Hz	0.4 Hz

**Wideband (No Anti-Alias Protection)<sup>(1)</sup>**

When wideband is selected, there is neither an analog anti-alias filter nor any digital filter in the signal path. Therefore, there is no anti-alias protection when wideband is selected.

Wideband bandwidth	Between 1.0 MHz and 1.35 MHz (-3 dB)
0.1 dB passband flatness <sup>(2)</sup>	DC to 160 kHz

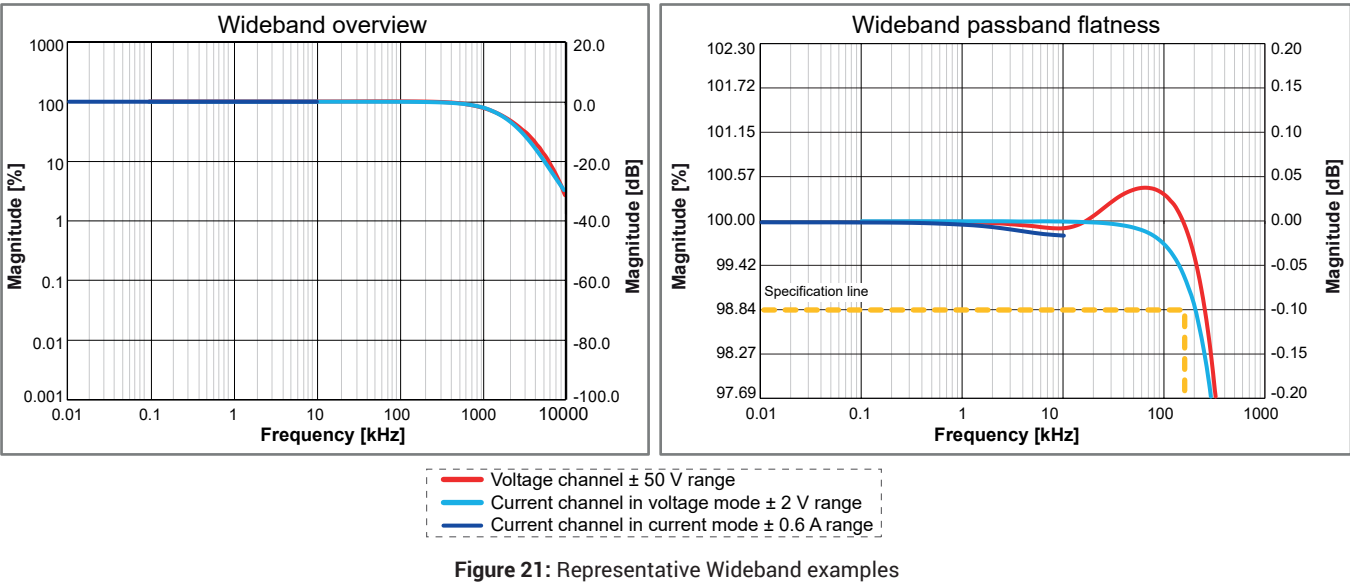

(1) Wideband (No Anti-Alias Protection) filter is valid for GN310B only.

(2) Measured using a Fluke 5700A calibrator, DC normalized.

Bessel Filter (Analog Anti-Alias)<sup>(1)</sup>

Figure 22: Bessel Filter

When Bessel filter is selected, this is only the analog Bessel anti-alias filter and not a digital filter.

Bessel filter bandwidth	395 kHz $\pm$ 25 kHz (-3 dB)
Bessel filter characteristic	7-pole Bessel, optimal step response
Bessel filter 0.1 dB passband flatness <sup>(2)</sup>	DC to 60 kHz
Stopband magnitude ( $\delta_s$ ) at frequency ( $\omega_s$ )	-60 dB at $\omega_s = 2.0$ MHz
Bessel filter roll-off	42 dB/Octave

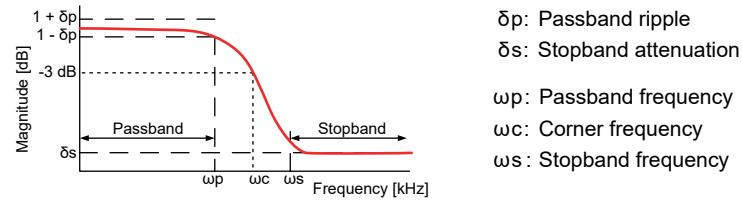
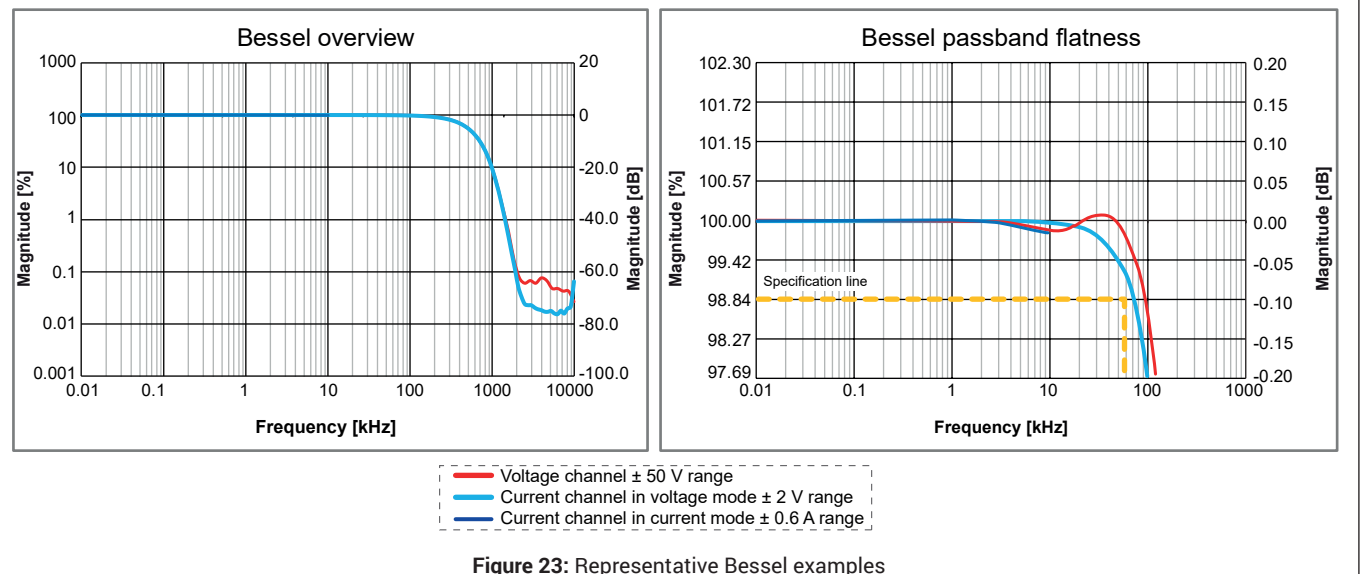

Figure 23: Representative Bessel examples

- (1) Analog Anti-Alias Bessel filter is valid for GN310B only.  
 (2) Measured using a Fluke 5700A calibrator, DC normalized.

Butterworth Filter (Analog Anti-Alias)<sup>(1)</sup>

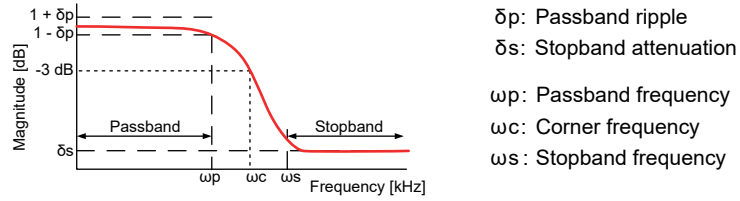

Figure 24: Butterworth Filter

When Butterworth filter is selected, this is only the analog Butterworth anti-alias filter and not a digital filter.

Butterworth filter bandwidth	460 kHz $\pm$ 25 kHz (-3 dB)
Butterworth filter characteristic	7-pole Butterworth, optimal frequency response
Butterworth filter 0.1 dB passband flatness <sup>(2)</sup>	DC to 130 kHz
Stopband magnitude ( $\delta_s$ ) at frequency ( $\omega_s$ )	-60 dB at $\omega_s = 1.1$ MHz
Butterworth filter roll-off	42 dB/Octave

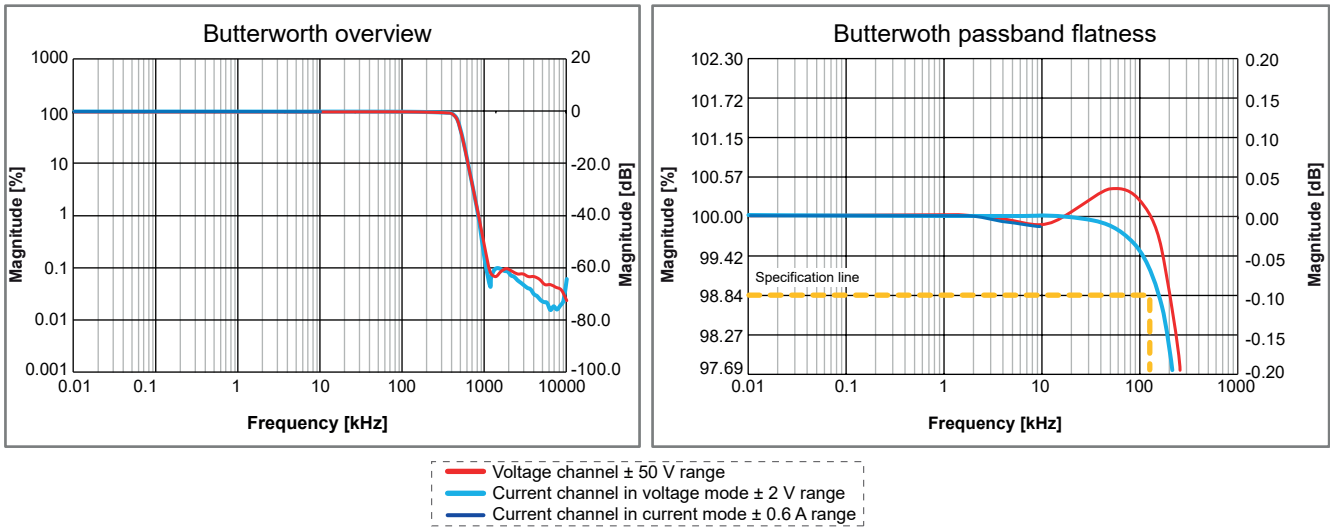

Figure 25: Representative Butterworth examples

(1) Analog Anti-Alias Butterworth filter is valid for GN310B only.

(2) Measured using a Fluke 5700A calibrator, DC normalized.

Bessel IIR Filter (Digital Anti-Alias)

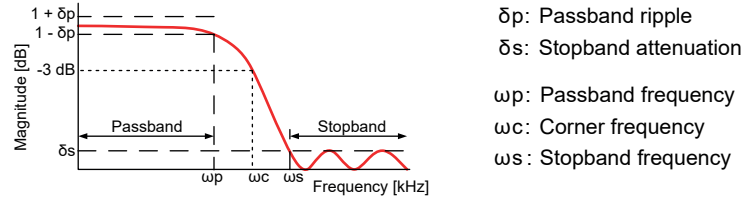

Figure 26: Digital Bessel IIR Filter (200 kHz for GN310B only; 20 kHz for GN310B and GN311B)

When Bessel IIR filter is selected, this is always a combination of an analog Bessel anti-alias filter and a digital Bessel IIR filter.

Analog anti-alias filter bandwidth	395 kHz $\pm$ 25 kHz (-3 dB)
Analog anti-alias filter characteristic	7-pole Bessel, optimal step response
Bessel IIR filter characteristic	8-pole Bessel style IIR
Bessel IIR filter user selection	Auto tracking for sample rate divided by: 10, 20, 40, 100 The user selects a division factor from the current sample rate; software then adjusts the filter when the sample rate is changed.
Bessel IIR filter bandwidth ( $\omega_c$ )	User selectable from 0.4 Hz to 200 kHz (or 20 kHz for GN311B)
Bessel IIR 0.1 dB passband ( $\omega_p$ ) <sup>(1)</sup>	DC to 0.14 * $\omega_c$
Bessel IIR filter stopband attenuation ( $\delta_s$ )	55 dB
Bessel IIR filter roll-off	48 dB/octave

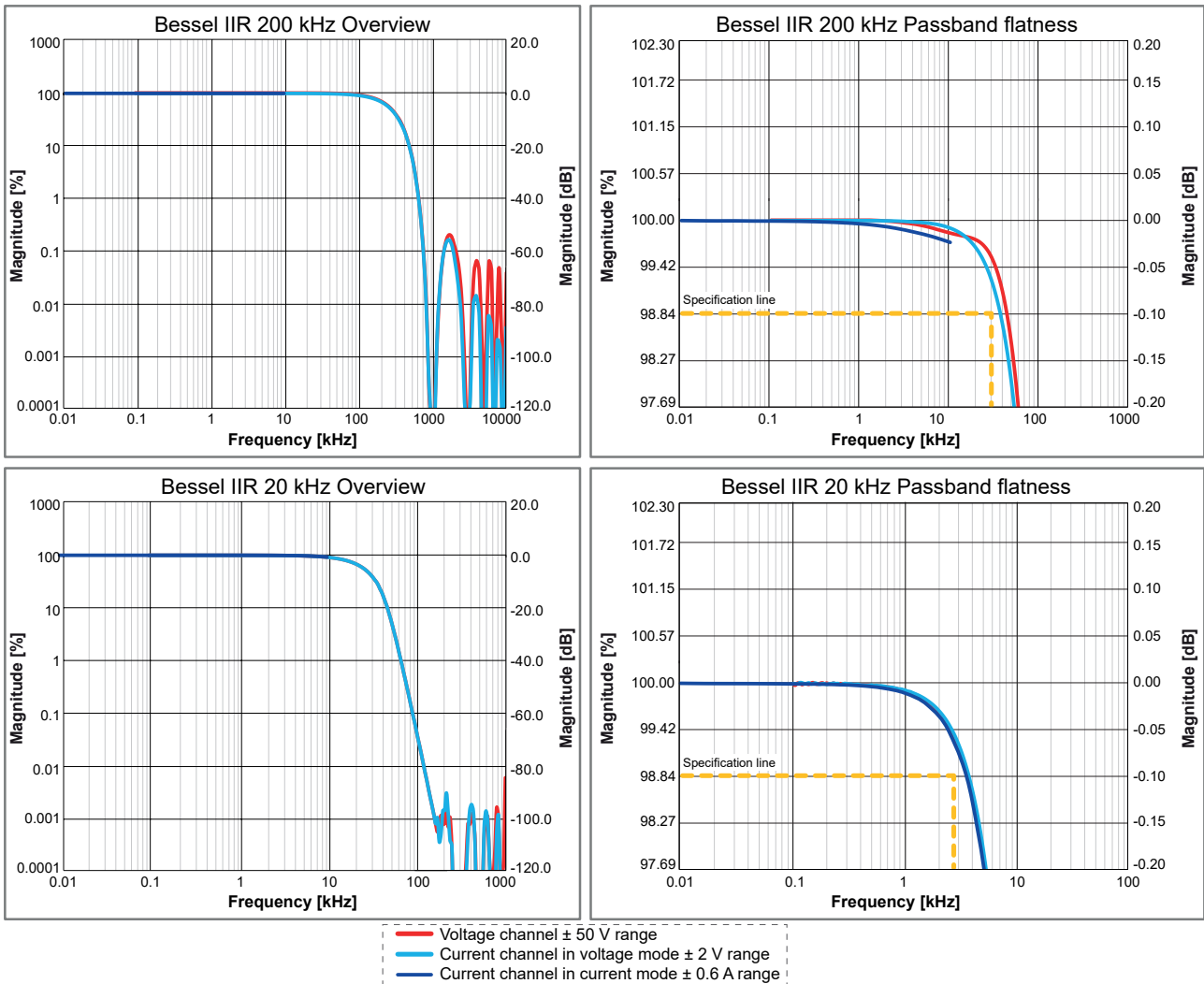

Figure 27: Representative Bessel IIR examples (200 kHz for GN310B only; 20 kHz for GN310B and GN311B)

(1) Measured using a Fluke 5700A calibrator, DC normalized

Butterworth IIR Filter (Digital Anti-Alias)

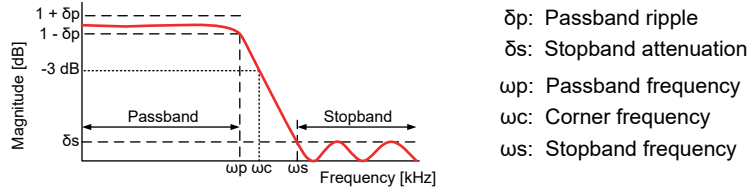

Figure 28: Digital Butterworth IIR Filter

When Butterworth IIR filter is selected, this is always a combination of an analog Bessel anti-alias filter and a digital Butterworth IIR filter.

Analog anti-alias filter bandwidth	460 kHz $\pm$ 25 kHz (-3 dB)
Analog anti-alias filter characteristic	7-pole Bessel, extended passband response
Butterworth IIR filter characteristic	8-pole Butterworth style IIR
Butterworth IIR filter user selection	Auto tracking for sample rate divided by: 4 <sup>(1)</sup> , 10, 20, 40 The user selects a division factor from the current sample rate; software then adjusts the filter when the sample rate is changed
Butterworth IIR filter bandwidth ( $\omega_c$ )	User selectable from 1 Hz to 250 kHz (or 50 kHz for GN311B)
Butterworth IIR 0.1 dB passband ( $\omega_p$ ) <sup>(2)</sup>	DC to 0.7 * $\omega_c$ (for $\omega_c > 100$ kHz, DC to 0.6 * $\omega_c$ , due to analog anti-alias filter bandwidth)
Butterworth IIR filter stopband attenuation ( $\delta_s$ )	60 dB
Butterworth IIR filter roll-off	48 dB/octave

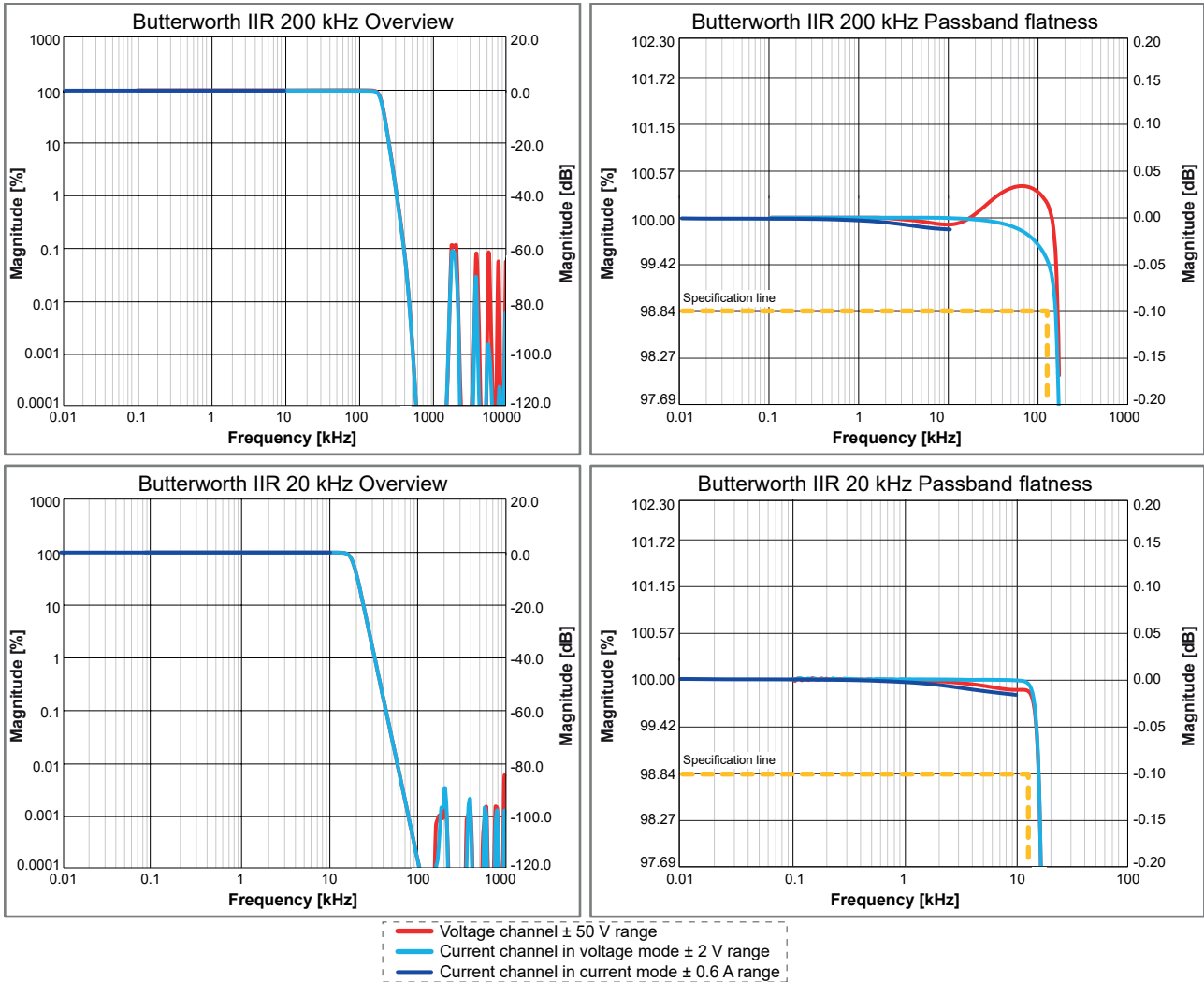

Figure 29: Representative Butterworth IIR examples (200 kHz for GN310B only; 20 kHz for GN310B and GN311B)

- (1) Division by 4 not possible for the 2 MS/s sample rate
- (2) Measured using a Fluke 5700A calibrator, DC normalized

Elliptic IIR Filter (Digital Anti-Alias)

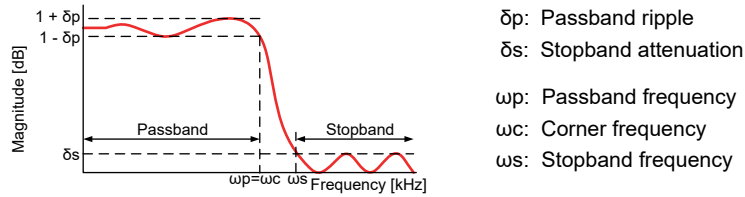

Figure 30: Digital Elliptic IIR Filter

When Elliptic IIR filter is selected, this is always a combination of an analog Butterworth anti-alias filter and a digital Elliptic IIR filter.

Analog anti-alias filter bandwidth	460 kHz $\pm$ 25 kHz (-3 dB)
Analog anti-alias filter characteristic	7-pole Butterworth, extended passband response
Elliptic IIR filter characteristic	7-pole Elliptic style IIR
Elliptic IIR filter user selection	Auto tracking for sample rate divided by: 4 <sup>(1)</sup> , 10, 20, 40 The user selects a division factor from the current sample rate; software then adjusts the filter when the sample rate is changed
Elliptic IIR filter bandwidth ( $\omega c$ )	User selectable from 1 Hz to 250 kHz (or 50 kHz for GN311B)
Elliptic IIR 0.1 dB passband ( $\omega p$ ) <sup>(2)</sup>	DC to $\omega c$ (for $\omega c > 100$ kHz, DC to $0.7 * \omega c$ due to analog anti-alias filter bandwidth)
Elliptic IIR filter stopband attenuation ( $\delta s$ )	60 dB
Elliptic IIR filter roll-off	72 dB/octave

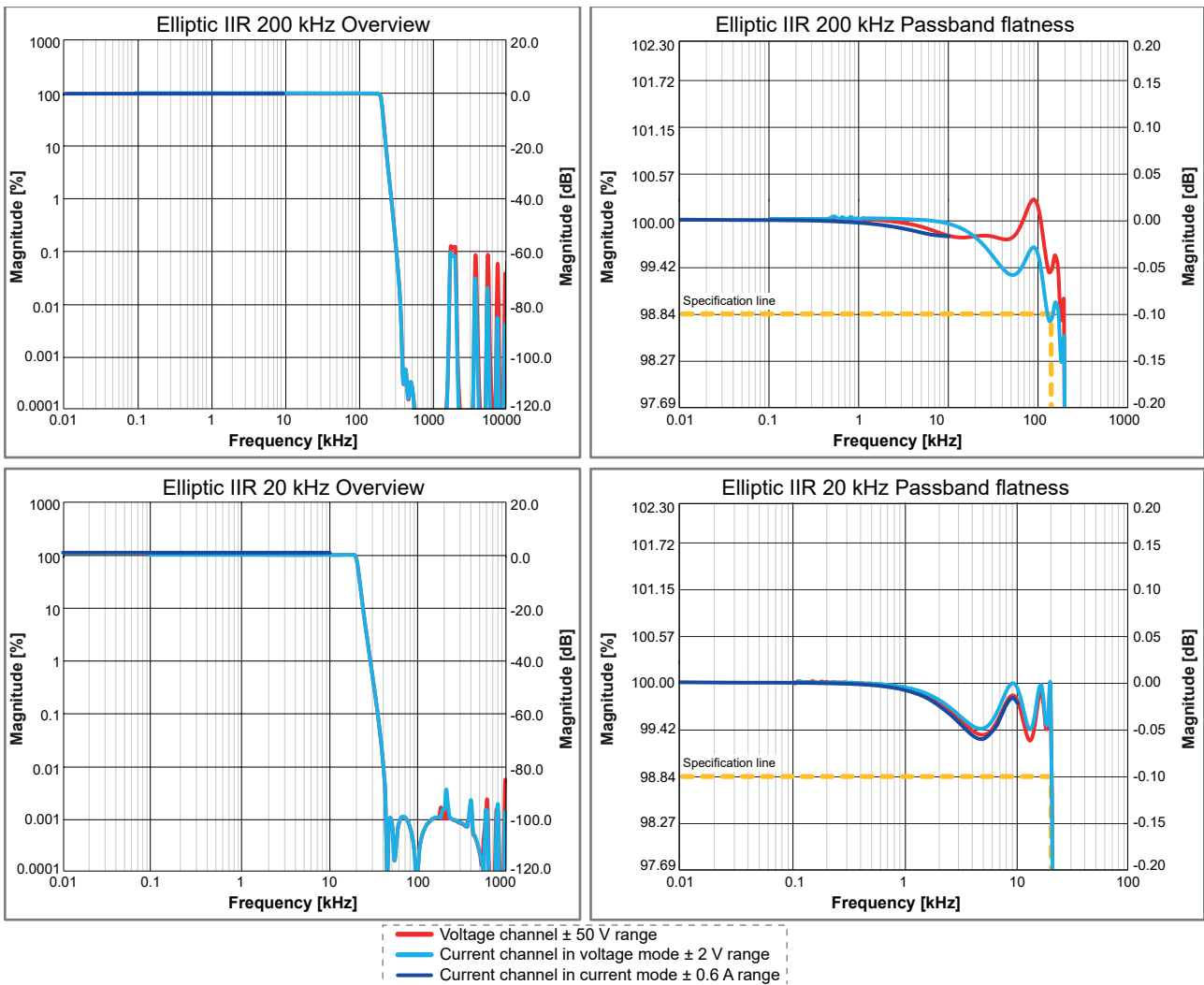

Figure 31: Representative Elliptic IIR examples (200 kHz for GN310B only; 20 kHz for GN310B and GN311B)

- (1) Division by 4 not possible for the 2 MS/s sample rate
- (2) Measured using a Fluke 5700A calibrator, DC normalized

**Channel to Channel Phase Match**

Using different filter selections (Wideband/Bessel IIR/Butterworth IIR/etc.) or different filter bandwidths results in phase mismatches between channels. All specifications are Pass/Fail limits for sine wave signals with frequency  $f$ , measured at 2 MS/s sample rate.

	$f \leq 1 \text{ kHz}$	$1 \text{ kHz} < f \leq 10 \text{ kHz}$	$10 \text{ kHz} < f \leq 100 \text{ kHz}$
<b>Wideband</b>			
Channels within group	$\pm 0.01^\circ$	$\pm 0.03^\circ$	$\pm 0.1^\circ$
Channels between groups on card	$\pm 0.02^\circ$	$\pm 0.1^\circ$	$\pm 0.7^\circ$
GN310B Channels within mainframe	$\pm 0.02^\circ$	$\pm 0.1^\circ$	$\pm 0.8^\circ$
<b>Bessel IIR, Filter frequency 200 kHz</b>			
Channels within group	$\pm 0.01^\circ$	$\pm 0.04^\circ$	$\pm 0.3^\circ$
Channels between groups on card	$\pm 0.02^\circ$	$\pm 0.1^\circ$	$\pm 1.0^\circ$
GN310B Channels within mainframe	$\pm 0.02^\circ$	$\pm 0.1^\circ$	$\pm 1.2^\circ$
<b>Butterworth IIR, Filter frequency 200 kHz</b>			
Channels within group	$\pm 0.01^\circ$	$\pm 0.04^\circ$	$\pm 0.3^\circ$
Channels between groups on card	$\pm 0.02^\circ$	$\pm 0.1^\circ$	$\pm 1.0^\circ$
GN310B Channels within mainframe	$\pm 0.02^\circ$	$\pm 0.1^\circ$	$\pm 1.2^\circ$
<b>Elliptic IIR, Filter frequency 200 kHz</b>			
Channels within group	$\pm 0.01^\circ$	$\pm 0.04^\circ$	$\pm 0.3^\circ$
Channels between groups on card	$\pm 0.02^\circ$	$\pm 0.1^\circ$	$\pm 1.0^\circ$
GN310B Channels within mainframe	$\pm 0.02^\circ$	$\pm 0.1^\circ$	$\pm 1.2^\circ$
GN310B channels across mainframes	Defined by synchronization method used (None, IRIG, GPS, Master/Sync, PTP)		

## Channel to Channel Crosstalk

Channel to channel crosstalk is measured with a 50  $\Omega$  termination resistor on the input and uses sine wave signals adjacent channel(s). Crosstalk from current channels (current mode or voltage mode) to voltage channels is too small to measure, well below -100 dB.

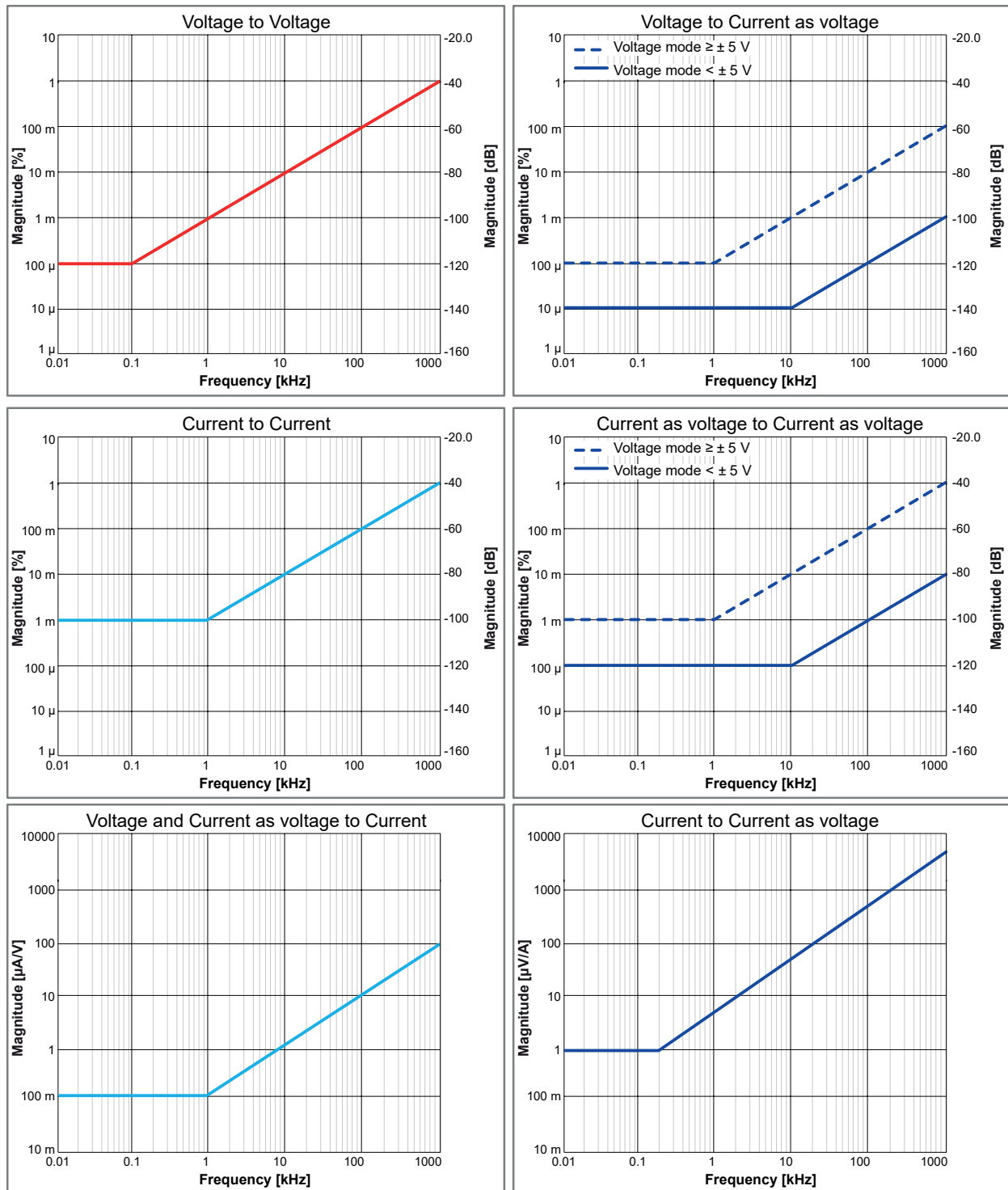
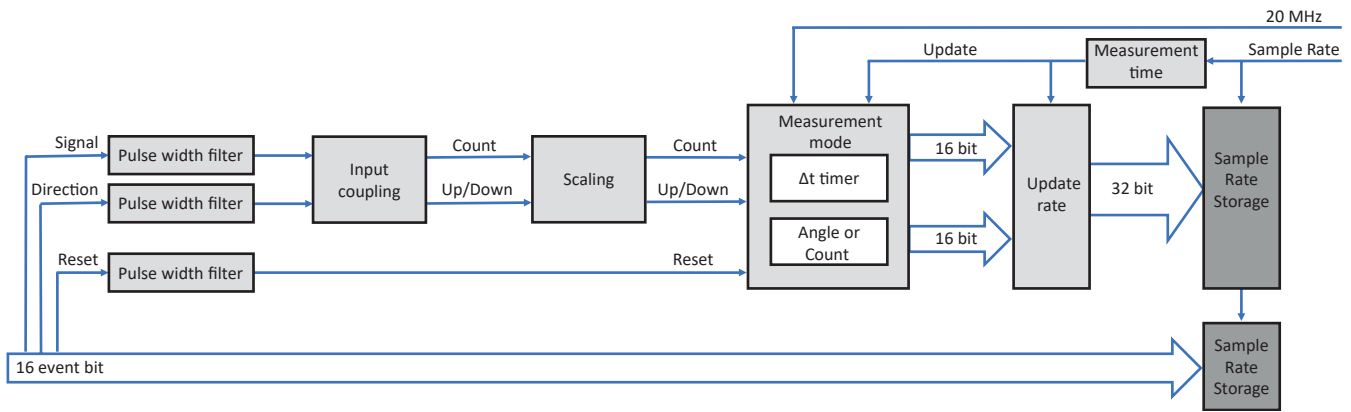

Figure 32: Representative Channel to Channel crosstalk

**Digital Event/Timer/Counter**

The Digital Event/Timer/Counter input connector is located on the mainframe. For exact layout and pinning see mainframe data sheet.



**Figure 33:** Timer/Counter block diagram

Digital input events	16 per card
Levels	TTL input level, user programmable invert level
Inputs	1 pin per input, some pins are shared with Timer/Counter inputs
Overtolerance protection	± 30 V DC continuously
Minimum pulse width	100 ns
Maximum frequency	5 MHz
Digital output events	2 per card
Levels	TTL output levels, short circuit protected
Output event 1	User selectable: Trigger, Alarm, set High or Low
Output event 2	User selectable: Recording active, set High or Low
<b>Digital output event user selections</b>	
Trigger	1 high pulse per trigger (on every channel trigger of this card only) 12.8 μs minimum pulse width 200 μs ± 1 μs ± 1 sample period pulse delay
Alarm	High when alarm condition of card is activated, low when not activated 200 μs ± 1 μs ± 1 sample period alarm event delay
Recording active	High when recording, low when in Idle or Pause mode Recording active output delay of 450 ns
Set High or Low	Output set High or Low; can be controlled by Custom Software Interface (CSI) extensions; delay depends on specific software implementation
Timer/Counter	4 per card
Levels	TTL input levels
Inputs	3 pins: signal, reset and direction All pins are shared with digital event inputs
Input coupling	Uni-directional, Bi-directional and ABZ incremental encoder (Quadrature)
Measurement modes	Count (C) Angle (0 to 360 degrees) Frequency (Δcount / Δt) RPM (Δcount / Δt / 60 s)
Timer accuracy	± 25 ns (20 MHz)
Measurement time	1 to n samples (User selectable maximum Δt)
Measurement time and reading update rate	Measurement time sets the maximum update rate of the Measurement values
Measurement time and minimum frequency	Minimum measured frequency or RPM = 1 / Measurement time

## Input Coupling Uni- and Bi-directional Signal

Uni- and bi-directional input coupling is used when the direction signal is a stable signal.

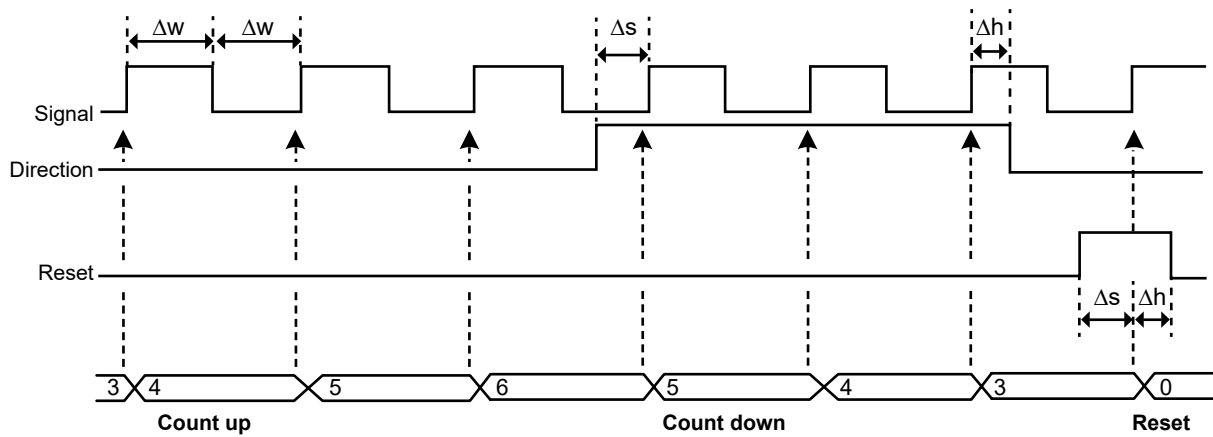
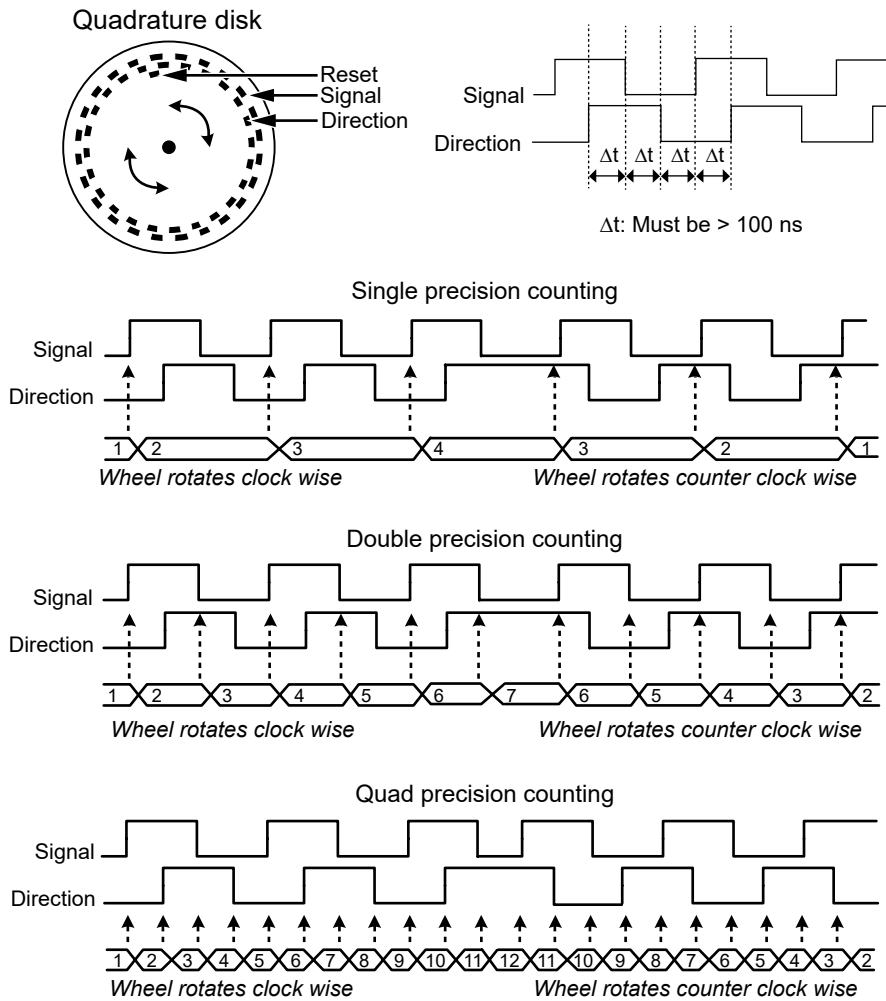

Figure 34: Uni- and Bi-directional timing

Inputs	3 pins: signal, reset and direction (only used in bi-directional count)	
Minimum pulse width filter	100 ns, 200 ns, 500 ns, 1 $\mu$ s, 2 $\mu$ s, 5 $\mu$ s	
Maximum input signal frequency	4 MHz	
Minimum pulse width ( $\Delta w$ )	100 ns	
<b>Reset input</b>		
Level sensitivity	User selectable invert level	
Minimum setup time prior to signal edge ( $\Delta s$ )	100 ns	
Minimum hold time after signal edge ( $\Delta h$ )	100 ns	
<b>Reset options</b>		
Manual	Upon user request by software command	
Start recording	Count value set to 0 at Start of recording	
First reset pulse	After the recording is started, the first reset pulse sets the counter value to 0. The next reset pulses are ignored.	
Each reset pulse	On each external reset pulse, the counter value is reset to 0.	
<b>Direction input</b>		
Input Level sensitivity	Only used when in bi-directional mode Low: increment counter/positive frequency High: decrement counter/negative frequency	
Minimum setup time prior to signal edge ( $\Delta s$ )	100 ns	
Minimum hold time after signal edge ( $\Delta h$ )	100 ns	

**Input Coupling ABZ Incremental Encoder (Quadrature)**

Typically used for tracking rotating/moving devices using a decoder with two signals that are always 90 degree phase shifted. E.g. allow for direct interfacing to HBK torque and speed transducers.



**Figure 35: Bi-directional quadrature count modes**

Inputs	3 pins: signal, direction and reset	
Minimum pulse width filter	100 ns, 200 ns, 500 ns, 1 μs, 2 μs, 5 μs	
Maximum input signal frequency	2 MHz	
Minimum pulse width	200 ns (2 * Δt)	
Minimum setup time	100 ns (Δt)	
Minimum hold time	100 ns (Δt)	
Accuracy	Single (X1), dual (X2) or quad (X4) precision	
Input coupling	ABZ incremental encoder (Quadrature)	
<b>Reset input</b>		
Level sensitivity	User selectable invert level	
Minimum setup time prior to signal edge (Δt)	100 ns	
Minimum hold time after signal edge (Δt)	100 ns	
<b>Reset options</b>		
Manual	Upon user request by software command	
Start recording	Count value set to 0 at Start of recording	
First reset pulse	After the recording is started, the first reset pulse sets the counter value to 0. The next reset pulses are ignored.	
Each reset pulse	On each external reset pulse, the counter value is reset to 0.	

### Measurement Mode Angle

In angle measurement mode the counter will use a user defined maximum angle and revert back to zero when this count value is reached. Using the reset input the measured angle can be synchronized to the mechanical angle. The real-time calculators can extract the RPM from the measured angle independent from the mechanical synchronization.

#### Angle options

Reference	User selectable. Enables the use of the reset pin to reference the mechanical angle to the measured angle
Angle at reference point	User defined to specify mechanical reference point
Reset pulse	Angle value is reset to user defined "angle at reference point" value
Pulses per rotation	User defined to specify the encoder/count resolution
Maximum pulses per rotation	32767
Maximum RPM	30 * sample rate (Example: Sample rate 10 kS/s means maximum 300 k RPM)

### Measurement Mode Frequency/RPM

Used to measure any kind of frequency like engine RPM, or active sensors with proportional frequency output signal.

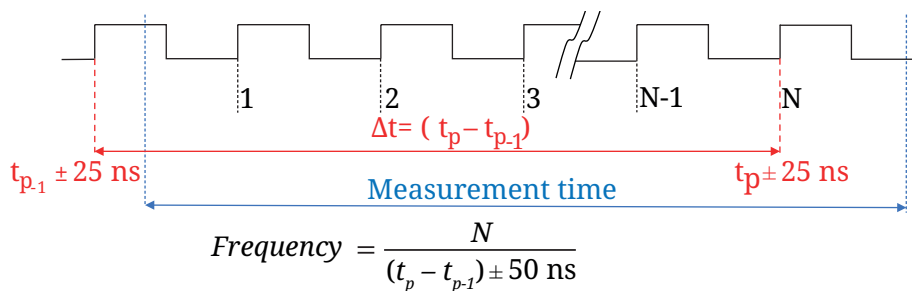

Figure 36: Frequency measurement

Accuracy	0.1%, when using a measurement time of 40 μs or more. With lower measurement times, the real-time calculators or Perception formula database can be used to enlarge the measurement time and improve the accuracy more dynamically e.g. based on measured cycles.
Measurement time	Sample period (1 / sample rate) to 50 s. Minimum measurement time is 50 ns. Can be selected by user to control update rate independent of sample rate

### Measurement Mode Count/Position

Count/position mode is typically used for tracking movement of device under test.

To reduce the sensitivity for count/position errors due to clock glitches use the minimum pulse width filter or enable the ABZ in stead of uni-/bipolar input coupling.

Counter range	0 to $2^{31}$ ; uni-directional count $-2^{31}$ to $+2^{31} - 1$ ; bi-directional count
---------------	--

**Frequency Measurement Inaccuracy**

Frequency measurement accuracy is a tradeoff between update rate and minimum required accuracy. This table shows the relationships between measured signal frequency, selected measurement time (update rate) and frequency accuracy. The inaccuracy distribution is to be considered rectangular.

Calculate the inaccuracy by using:<sup>(1)</sup>

$$Inaccuracy = \pm \frac{Signal\ frequency * \left( CEILING\left(\frac{Measuring\ time}{30000 * 50\ ns}\right) * 50\ ns \right)}{Frequency\ prescaler * FLOOR\left(\frac{Signal\ frequency * Measuring\ time}{Frequency\ prescaler}\right)} * 100\%$$

Measurement time	Higher signal frequencies: Signal frequency 2 MHz down to 10 kHz										
	Worst case (in %)	2 MHz	1 MHz	500 kHz	400 kHz	200 kHz	100 kHz	50 kHz	40 kHz	20 kHz	10 kHz
1 μs	±10.000 @ ~2 MHz <sup>(2)</sup>	±5.000%									
2 μs	±5.000 @ ~1 MHz <sup>(2)</sup>	±2.500%									
5 μs	±2.000 @ ~400 kHz <sup>(2)</sup>	±1.000%	±1.250%	±1.000%							
10 μs	±1.000 @ ~200 kHz <sup>(2)</sup>	±0.500%									
20 μs	±0.500 @ ~100 kHz <sup>(2)</sup>	±0.250%									
50 μs	±0.200 @ ~40 kHz <sup>(2)</sup>	±0.100%						±0.125%	±0.100%		
100 us	±0.100 @ ~20 kHz <sup>(2)</sup>	±0.050%									
200 us	±0.050 @ ~10 kHz <sup>(2)</sup>	±0.0250%									
500 us	±0.020 @ ~4 kHz <sup>(2)</sup>	±0.0100%									
1 ms	±0.0100 @ ~2 kHz <sup>(2)</sup>	±0.0050%									
2 ms	±0.0100 @ ~1 kHz <sup>(2)</sup>	±0.0050%									
5 ms	±0.0080 @ ~400 Hz <sup>(2)</sup>	±0.0040%									
10 ms	±0.0070 @ ~200 Hz <sup>(2)</sup>	±0.0035%									
20 ms	±0.0070 @ ~100 Hz <sup>(2)</sup>	±0.0035%									
50 ms	±0.0068 @ ~40 Hz <sup>(2)</sup>	±0.0034%									
100 ms	±0.0067 @ ~20 Hz <sup>(2)</sup>	±0.00335%									

Measurement time	Lower signal frequencies: Signal frequency 5 kHz down to 40 Hz										
	Worst case (in %)	5 kHz	4 kHz	2 kHz	1 kHz	500 Hz	400 Hz	200 Hz	100 Hz	50 Hz	40 Hz
500 us	±0.0200 @ ~4 kHz <sup>(2)</sup>	±0.0125%	±0.0100%								
1 ms	±0.0100 @ ~2 kHz <sup>(2)</sup>	±0.0050%									
2 ms	±0.0100 @ ~1 kHz <sup>(2)</sup>	±0.0050%									
5 ms	±0.0080 @ ~400 Hz <sup>(2)</sup>	±0.0040%			±0.00500%	±0.0040%					
10 ms	±0.0070 @ ~200 Hz <sup>(2)</sup>	±0.0035%									
20 ms	±0.0070 @ ~100 Hz <sup>(2)</sup>	±0.0035%									
50 ms	±0.0068 @ ~40 Hz <sup>(2)</sup>	±0.0034%								±0.0043%	±0.0034%
100 ms	±0.0067 @ ~20 Hz <sup>(2)</sup>	±0.00335%									

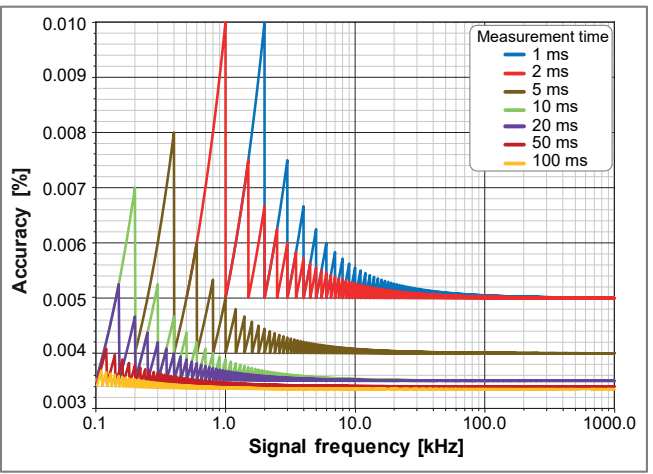
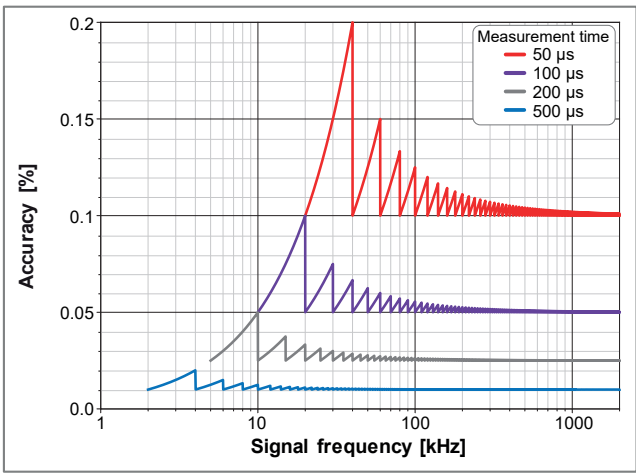

Figure 37: Maximum frequency inaccuracy

- (1) Note: Keep the Frequency PreScaler as small as possible for the selected frequency range to get the best accuracy.
- (2) The worst case scenario signal frequency is slightly below the displayed value, consistent with the sawtooth pattern observed in Figure 37.

## Torque Measurement Uncertainty using Frequency Measurements

When using the Timer/Counter channels to measure torque, the measurement uncertainty introduced by the timer inaccuracies can be calculated using the following examples based on HBK T40 torque transducers. The T40 torque transducer comes with 3 variants for frequency output: 10 kHz, 60 kHz or 240 kHz center frequency. From the datasheets you can extract the minimum and maximum frequency output like table below.

T40 Variant	-Full Scale frequency output	+Full Scale frequency output
T40 - 10 kHz	5 kHz	15 kHz
T40 - 60 kHz	30 kHz	90 kHz
T40 - 240 kHz	120 kHz	360 kHz

Overlay these operating ranges on top of the timer inaccuracy plots of Figure 37 will result in Figure 38 (see below).

- Remains the step to balance the update rate (torque bandwidth) versus the torque accuracy required.
- Calculate the inaccuracy using the Full Scale frequency output and desired measurement time.

Selected measurement time	Maximum inaccuracy: T40 - 240 kHz	Maximum inaccuracy: T40 - 60 kHz	Maximum inaccuracy: T40 - 10 kHz
50 $\mu$ s	0.1167%	0.2000%	Not possible
100 $\mu$ s	0.0542%	0.0667%	Not possible
500 $\mu$ s	0.0102%	0.0107%	0.0150%
1 ms	0.0050%	0.0052%	0.0060%
2 ms	0.0050%	0.0051%	0.0055%
5 ms	0.0040%	0.0040%	0.0042%

For K=1 (70% probability) use the specified rectangular distribution and the maximum inaccuracy numbers and calculate:

Measurement uncertainty = Maximum inaccuracy \* 0.58 (Conversion for rectangular distribution)

Measurement uncertainty K=1 (About 70% probability)	Maximum inaccuracy: T40 - 240 kHz	Maximum inaccuracy: T40 - 60 kHz	Maximum inaccuracy: T40 - 10 kHz
50 $\mu$ s	0.0677%	0.1160%	Not possible
100 $\mu$ s	0.0314%	0.0387%	Not possible
500 $\mu$ s	0.0059%	0.0062%	0.0087%
1 ms	0.0029%	0.0030%	0.0035%
2 ms	0.0029%	0.0029%	0.0032%
5 ms	0.0023%	0.0023%	0.0024%

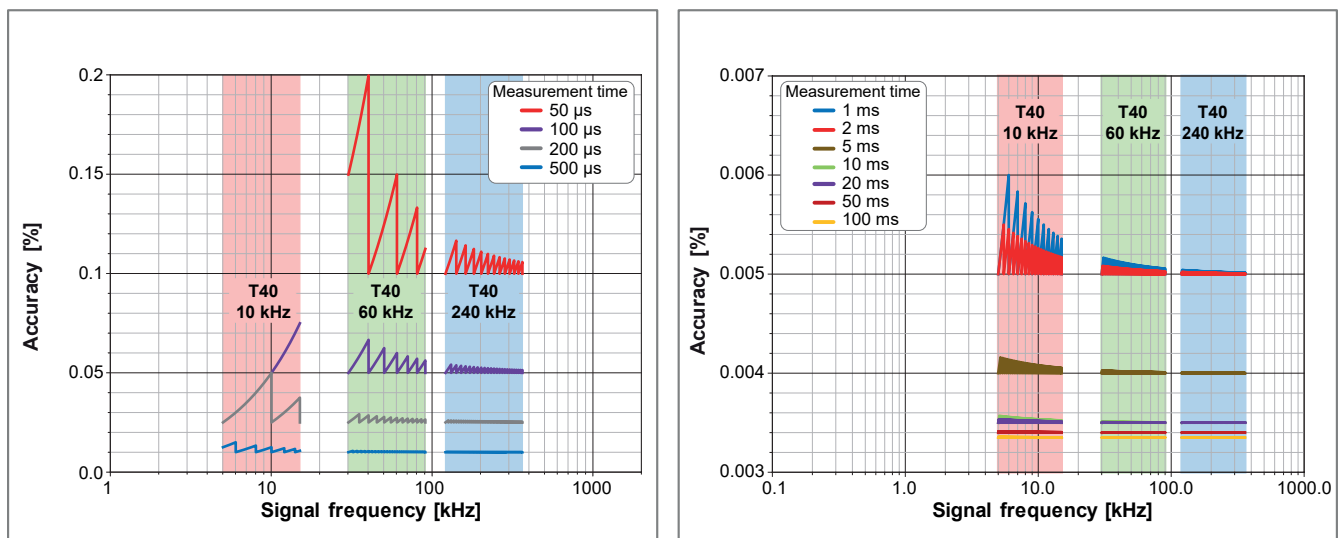

Figure 38: Torque operating range versus inaccuracy and measurement time

**Speed (RPM) Measurement Uncertainty using Frequency Measurements**

When using the Timer/Counter channels to measure speed (RPM), the measurement uncertainty introduced by the timer inaccuracies can be calculated using the following example.

In the datasheet of the speed sensor locate the specified number of pulse per rotation to calculate the frequency range of the sensor output:

Minimum frequency = minimum RPM used during testing \* number of pulse per rotation / 60 sec  
 Maximum frequency = maximum RPM used during testing \* number of pulse per rotation / 60 sec

Speed Sensor pulse per rotation	Frequency at 60 RPM	Frequency at 10000 RPM	Frequency at 30000 RPM
180	180 Hz	30 kHz	90 kHz
360	360 Hz	60 kHz	180 kHz
1024	1024 Hz	170.7 kHz	512 kHz

Overlay these operating ranges on top of the timer inaccuracy plots of Figure 37 will result in Figure 39 (see below).

- Remains the step to balance the update rate (RPM change updates per second) versus the RPM accuracy required.
- Using the graphs find the crossings of the overlaid operating frequencies with the measurement time curves.
- As examples the following crossings can be found in the graphs (at 60 RPM).

Selected measurement time	180 pulse sensor	360 pulse sensor	1024 pulse sensor
2 ms	Can't record at 60 RPM	Can't record at 60 RPM	0.0051%
5 ms	Can't record at 60 RPM	0.0072%	0.0041%
10 ms	0.0063%	0.0042%	0.0036%

For K=1 (70% probability) use the specified rectangular distribution and the maximum inaccuracy numbers and calculate:

Measurement uncertainty = Maximum inaccuracy \* 0.58 (Conversion for rectangular distribution)

Measurement uncertainty K=1 (About 70% probability)	180 pulse sensor	360 pulse sensor	1024 pulse sensor
2 ms	Can't record at 60 RPM	Can't record at 60 RPM	0.0030%
5 ms	Can't record at 60 RPM	0.0042%	0.0024%
10 ms	0.0037%	0.0024%	0.0021%

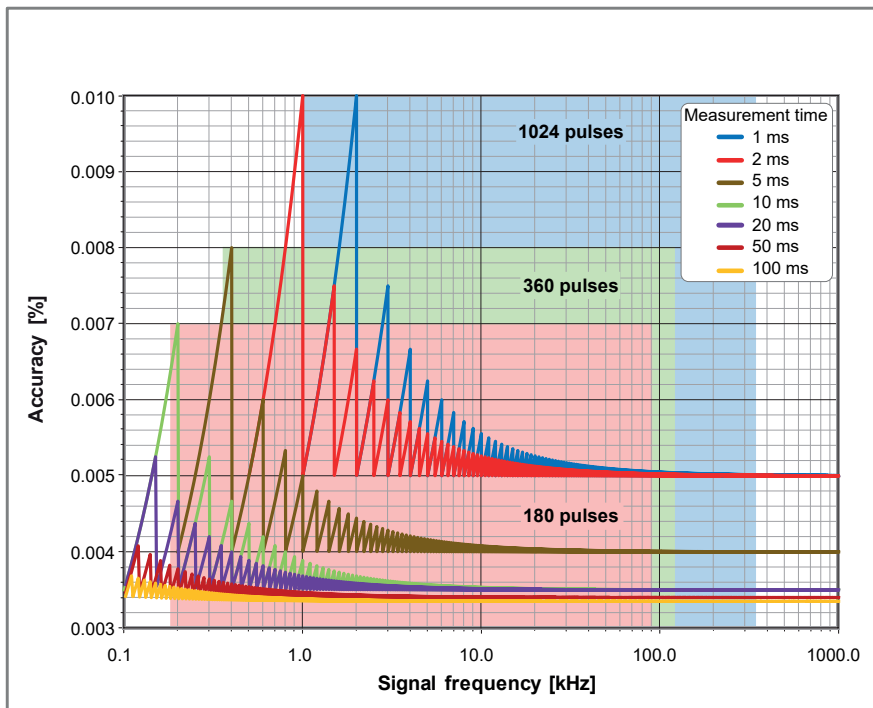

Figure 39: RPM sensor operating range versus inaccuracy and measurement time

### Simultaneous Dynamic Torque Ripple and Accurate Torque Efficiency Measurement

If a high update rate is required to measure e.g. dynamic torque ripple yet for efficiency a high accuracy is required use both a measurement time of 50  $\mu$ s as well as a RT-FDB function to calculate the mean value for each electric cycle. The measured torque signal coming from the timer counter will be 0.15 to 0.17% accurate, while the torque calculate for the electric cycle (typically being 1 ms or less) results in 0.0075% accuracy. As both signals are simultaneously available, the dynamic signal allows you to analyse the torque ripple behaviour, the electric cycle signal will be extremely accurate for efficiency calculations.

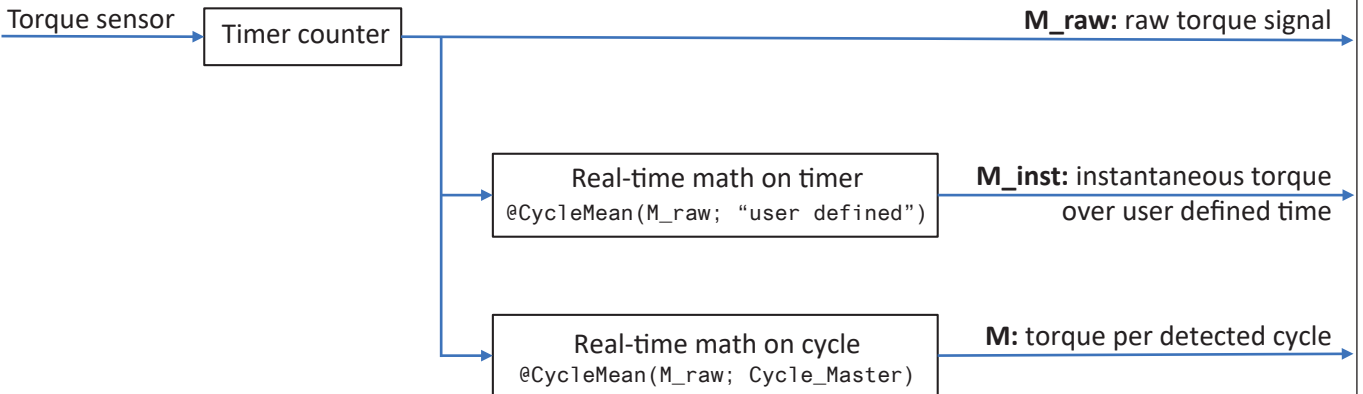

Figure 40: Simultaneous dynamic and accurate torque calculations

ePower signals	Application use	Dynamic response	Accuracy
M_raw	Torque ripple	Highest	Lowest
M_inst	Torque mean	Average	Average
M	Efficiency calculation	Lowest	Highest

### Alarm Output

Event channel alarm modes	High or low level check	
Cross channel alarms	Logical OR of alarms from all measured channels	
Alarm output	Active during valid alarm condition, output supported through mainframe	
Alarm output level	High or low user selectable	
Alarm output delay	515 $\mu$ s $\pm$ 1 $\mu$ s + maximum 1 sample period. Default 516 $\mu$ s, compatible with standard behavior. Minimum selectable delay is the smallest delay available for all acquisition cards used within the mainframe. Delay equal to Trigger Out delay.	
Selection per card	User selectable On/Off	
Analog channel alarm modes		
	Basic	Above or below level check
	Dual	Outside or within bounds check
Analog channel alarm levels		
	Levels	Maximum 2 level detectors
	Resolution	16 bit (0.0015%) for each level

Triggering	
Channel trigger/qualifier	1 per channel; fully independent per channel, software selectable either trigger or qualifier
Pre- and post-trigger length	0 to full memory
Maximum trigger rate	400 triggers per second
Maximum delayed trigger	1000 seconds after a trigger occurred
Manual trigger (Software)	Supported
External Trigger In	
Selection per card	User selectable On/Off
Trigger In edge	Rising/Falling mainframe selectable, identical for all cards
Minimum pulse width	500 ns
Trigger In delay	$\pm 1 \mu\text{s}$ + maximum 1 sample period
Send to External Trigger Out	User can select to forward External Trigger In to the External Trigger Out BNC
External Trigger Out	
Selection per card	User selectable On/Off
Trigger Out level	High/Low/Hold High; mainframe selectable, identical for all cards
Trigger Out pulse width	High/Low: 12.8 $\mu\text{s}$ Hold High: Active from first mainframe trigger to end of recording Pulse width created by mainframe; For details, please refer to the mainframe data sheet
Trigger Out delay	Selectable (10 $\mu\text{s}$ to 516 $\mu\text{s}$ ) $\pm 1 \mu\text{s}$ + maximum 1 sample period Default 516 $\mu\text{s}$ , compatible with standard behavior. Minimum selectable delay is the smallest delay available for all acquisition cards used within the mainframe
Cross channel triggering	
Measurement channels	Logical OR of triggers from all measured signals Logical AND of qualifiers from all measured signals
Calculated channels	Logical OR of triggers from all calculated signals (RT-FDB) Logical AND of qualifiers from all calculated signals (RT-FDB)
Analog channel trigger levels	
Levels	Maximum 2 level detectors
Resolution	16 bit (0.0015%) for each level
Direction	Rising/Falling; single direction control for both levels based on selected mode
Hysteresis	0.1 to 100% of Full Scale; defines the trigger sensitivity
Pulse detect/reject	Disable/Detect/Reject selectable. Maximum pulse width 65 535 samples
Analog channel trigger modes	
Basic	POS or NEG crossing; single level
Dual Level	One POS and one NEG crossing; two individual levels, logical OR
Analog channel qualifier modes	
Basic	Above or below level check. Enable/Disable trigger with single level
Dual	Outside or within bounds check. Enable/Disable trigger with dual level
Event channel trigger	
Event channels	Individual event trigger per event channel
Levels	Trigger on rising edge, falling edge or both edges
Qualifiers	Active High or Active Low for every event channel

On-board Memory	
Per card	2 GB (1 GS @ 16 bits, 500 MS @ 18 bits storage)
Organization	Automatically distributed amongst channels enabled for storage or real-time calculations
Memory diagnostics	Automatic memory test when system is powered on but not recording
Storage sample size	User selectable 16 or 18 bits 16 bits, 2 bytes/sample 18 bits, 4 bytes/sample

## Real-time Formula Database Calculators

The real-time formula database (RT-FDB) offers an extensive set of math routines to enable almost any real-time mathematical challenge. The database structure enables the user to define a list of mathematical equations similar to the Perception review formula database.

The maximum supported sample rate is 4 MS/s<sup>(1)</sup>.

Different versions of Perception can enable more or less features as described in this table.

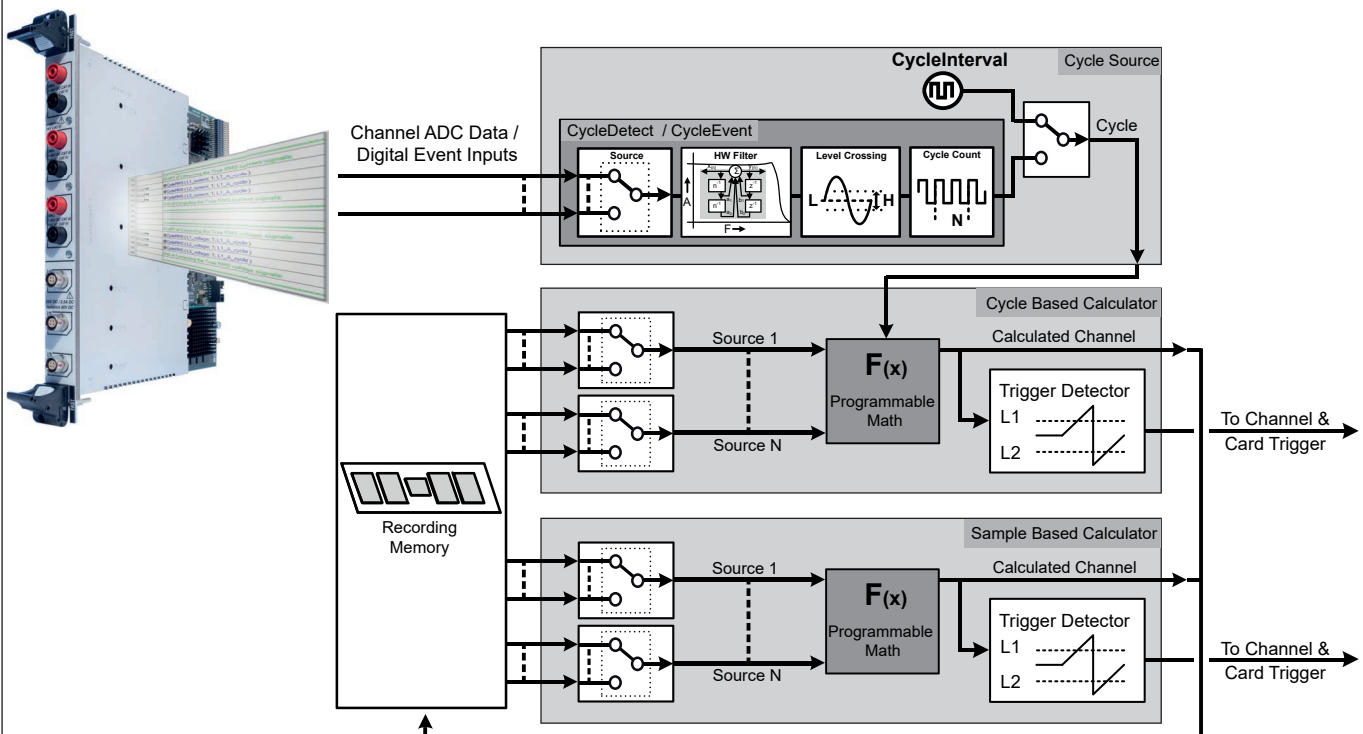

Figure 41: Real-time formula database (RT-FDB) calculators

The real-time formula database supports the following list of calculations (Details of each calculation are described in the Perception manual).

Cycle Source	Determines the periodic real-time calculation speed by either setting a timer or using a real-time cycle detect
Number of cycle sources	4; this is the maximum number of cycle sources that can be used per card in RT-FDB context.
<b>Cycle Source: Timer</b>	
Timer duration	0.5 ms (2 kHz) to 1 s (1 Hz)
<b>Cycle Source: Cycle detect</b>	
Level crossing	Real-time monitors one input channel using a signal level, hysteresis and direction to determine the cyclic nature of the signal
Cycle count	Sets the counted number of cycles used for periodic calculation output
Cycle period	Maximum Cycle period that can be detected: 1 s (1 Hz) Minimum Cycle period that can be detected: 0.5 ms (2 kHz) Calculations are stopped when the Cycle period gets outside its maximum- and minimum Cycle period (<0.5 ms or > 1 s).
Cycle Source: Cycle Event	Real-time monitors up to 2 Digital Input Events using the rising or falling edge to determine the cyclic nature of the event
Cycle Source: External Cycle Event	Real-time monitors External Event Input using the rising or falling edge to determine the cyclic nature of the event
<b>Trigger detector</b>	
Trigger output delay	Triggers are delayed by 100 ms on calculated signals. The trigger time is corrected internally so that the sweep triggering is correct. This reduces the maximum sweep length by 100 ms.

(1) Note: Sample rates > 2 MS/s only supported in combination with local storage and not supported in combination with GEN2tB and GEN3iA mainframes.

Real-time Formula Database Calculators			
Group	Available RT-FDB functions		
<b>Basic</b>			
	+ (add) - (subtract)	* (multiply) / (divide)	
<b>Boolean</b>			
	AlarmOnLevel And Equal GreaterEqualThan GreaterThan InsideBand	Not NotEqual OneShotTimer Or OutsideBand SetAlarm StartStopTriggerOnBooleanChange StopTriggerOnBooleanChange	ToAsyncBoolean TriggerArmOnBooleanChange TriggerOnBooleanChange TriggerOnLevel Xor
<b>Cycle</b>			
	CycleArea CycleBusDelay CycleCount CycleCrestFactor CycleDetect CycleEnergy CycleEvent CycleFrequency	CycleFundamentalPhase CycleFundamentalRMS CycleHarmonicPhase CycleHarmonicRMS CycleInterval CycleMax CycleMean CycleMin	CycleNOP CyclePeak2Peak CyclePhase CycleRMS CycleRPM CycleSampleCount CycleStdDev CycleTHD ExternalCycleEvent
<b>eDrive</b>			
	AronConversion DQ0Transformation EfficiencyMode	EfficiencyValue HarmonicsIEC61000 PowerLoss	SpaceVector SpaceVectorInv
<b>Enhanced</b>			
	Abs Atan Atan2 Cos DegreesToRadians Integrate IntegrateGated	LessEqualThan LessThan Max Min Minus Modulo PureDFT	RadiansToDegrees SampleCount Sin Sqrt Tan
<b>Fieldbus</b>			
	SetScalarFromFieldbus		
<b>Filter</b>			
	FilterBesselBP FilterBesselHP FilterBesselLP HWFilter	FilterButterworthBP FilterButterworthHP FilterButterworthLP	FilterChebyshevBP FilterChebyshevHP FilterChebyshevLP
<b>Math</b>			
	NumSamplesMean NumSamplesStdDev	TimedMean TimedStdDev	
<b>Signal generation</b>			
	Ramp Sinewave		

**Real-time Statstream®**

Patent Number : 7,868,886

Real-time extraction of basic signal parameters.

Supports real-time live scrolling and scoping waveform displays as well as real-time meters while recording.

During recording reviews, it enhances speed for displaying and zooming extremely large recordings and it reduces the calculation time for statistical values on large data sets.

Analog channels	Maximum, Minimum, Mean, Peak to Peak, Standard Deviation and RMS values
Event/Timer/Counter channels	Maximum, Minimum and Peak to Peak values

**Data Recording Modes**

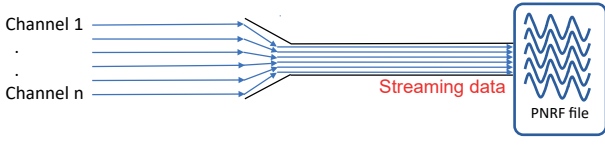
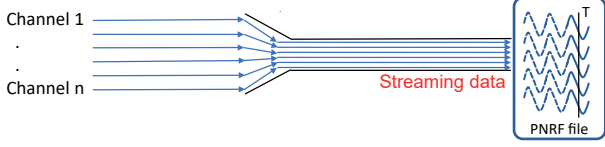
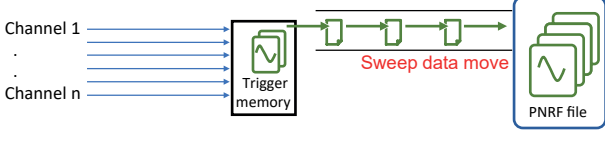
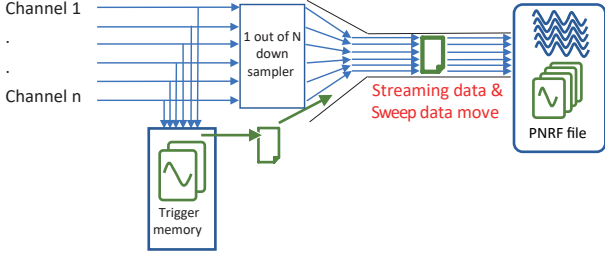
<p><b>On start of acquisition</b></p> 	<p>Recorded data is continuously streamed into the recording file on a mainframe or PC drive Data recording to a drive is limited by an <b>aggregate sample rate</b>, the recording time is limited by the <b>size of drive</b>. <b>Note:</b> As the aggregate sample rate limit depends on Ethernet speed and storage drive used, as well as the PC and drive not being used for other purposes as data recording, it is strongly recommended for higher aggregate sample rates to test the chosen setup prior to performing your test.</p>
<p><b>On trigger</b></p> 	<p>Recorded data is continuously streamed into the recording file on a mainframe or PC drive, but only the data before and after a single trigger event, the so-called 'pre-trigger' and 'post-trigger' data, is retained in the recording file. Trigger data recording to a drive is limited by an <b>aggregate sample rate</b>, the recording time is limited by the size of drive. <b>Note:</b> As the aggregate sample rate limit depends on Ethernet speed and storage drive used, as well as the PC and drive not being used for other purposes as data recording, it is strongly recommended for higher aggregate sample rates to test the chosen setup prior to performing your test. Not recommended for transient/one time only/destructive tests.</p>
<p><b>On trigger - buffered with Low rate Storage disabled</b></p> 	<p>Triggered data recording to trigger memory on the acquisition card. Triggered data recording to trigger memory has <b>no sample rate limits</b>, the recording time is limited by the <b>size of trigger memory</b>. Triggered data recorded in trigger memory is moved to a drive as quickly as possible. <b>Note:</b> This data recording mode guarantees the data will always be recorded according to the user defined settings. Recommended for transient/one time only/destructive tests.</p>
<p><b>On trigger - buffered with Low rate Storage enabled</b></p> 	<p>Data recording to PC or mainframe drive and simultaneous triggered data recording to trigger memory on the acquisition card. The <b>Low rate</b> data recording to a drive is limited by an <b>aggregate sample rate</b> and the recording time is limited by the <b>size of drive</b>. The triggered data recording to trigger memory has <b>no sample rate limits</b>, the triggered data recording time is limited by the <b>size of trigger memory</b>. The triggered data recorded in trigger memory is moved to a drive as quickly as possible. As this data move happens simultaneously with the <b>Low rate</b> data recording, it uses bandwidth of the aggregate sample rate. <b>Note:</b> As the aggregate sample rate limit depends on Ethernet speed and storage drive used, as well as the PC and drive not being used for other purposes as data recording, it is strongly recommended for higher aggregate sample rates as well as higher number of triggers per second to test the chosen setup prior to performing your test.</p>

**Data Recording Compared**

	Aggregate sample rate limit	Maximum recorded data	Direct recording to drive	Trigger memory first	Trigger required to start recording
On start of acquisition	Yes	Free drive space	Yes	No	No
On trigger	Yes	Free drive space	Yes	No	Yes
On trigger - buffered with Low rate Storage disabled	No	Trigger memory	No	Yes	Yes
On trigger - buffered with Low rate Storage enabled	Low rate: Yes	Free drive space	Yes	No	No
	High rate: No	Trigger memory	No	Yes	Yes

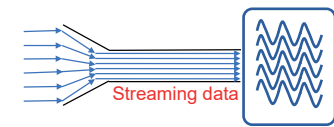

**Aggregate sample rate limits when using streaming data**

	<p>The maximum aggregate streaming rate per mainframe is defined by mainframe type and solid state drive, Ethernet speed, PC drive and other PC parameters. When an aggregate sample rate is higher than the aggregate streaming rate of the system is selected, the memory on each acquisition card acts as a FIFO. As soon as this FIFO fills up, the recording is suspended (no data is recorded temporarily). During this period, the FIFO memory is transferred to a drive. When all FIFO's are empty, the recording is automatically resumed. User notifications are added to the recording file for post recording identification of suspended recording.</p>
---	--

## Triggered Recording Definitions

The details in this table apply to the next recording modes:

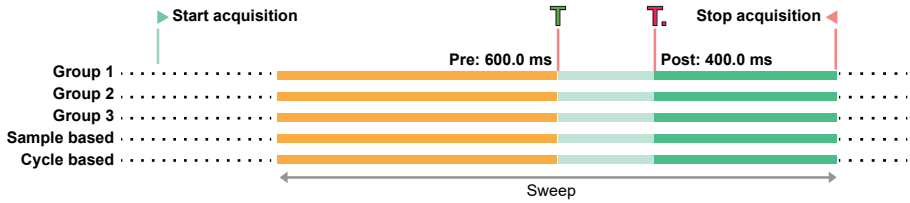
- On trigger
- On trigger - buffered with Low rate Storage disabled
- On trigger - buffered with Low rate Storage enabled

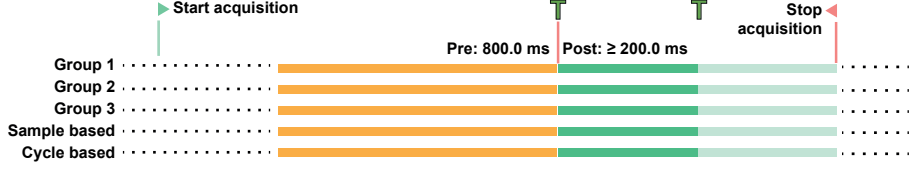
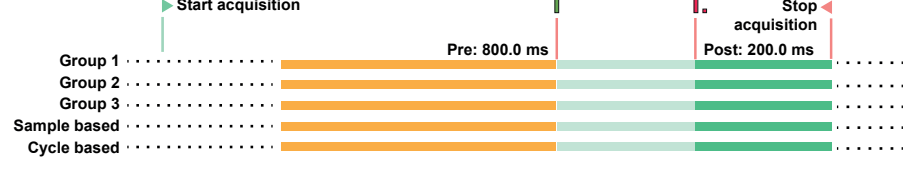
<p><b>Sweep</b></p> 	 <p>Defined by a trigger signal, pre- and post-trigger data and optionally between-trigger data and/or stop-trigger signal.</p>
<p><b>Triggered data segments</b></p>	
<p>Pre-trigger data</p>	<p>Data recorded prior to a trigger signal.  <b>Note:</b> If a trigger signal is received before the full length of pre-trigger data is recorded, the trigger is accepted and the pre-trigger data recorded is automatically reduced to the available pre-trigger data at the time of the trigger.</p>
<p>Post-trigger data</p>	<p>Data recorded after a trigger or stop-trigger signal.  <b>Note:</b> The recording of the post-trigger data can be re-started or delayed depending on the “<i>post-trigger begins on</i>” selection.</p>
<p>Between-trigger data</p>	<p>Data recorded due to re-trigger(s) or while waiting for the Stop-trigger.  The length of between-trigger data is not specified and added based on the timing of the trigger or stop-trigger signals.</p>
<p><b>Trigger signals</b></p>	
<p>Trigger signal</p>	<p>This signal ends the pre-trigger and starts the post-trigger data recording.  See table section “Post-trigger begins on” for more details.  A trigger signal can be set up on external input trigger, analog and digital channels as well as using simple to complex RT-FDB formulas.</p>
<p>Stop-trigger signal</p>	<p>This signal starts the post-trigger data recording when in “post-trigger begins on stop-trigger” mode.  See table section “Post-trigger begins on” for more details.  A stop-trigger signals can be set up on external input trigger and simple to complex RT-FDB formulas.</p>
<p><b>Post-trigger begins on</b></p>	
<p>First trigger</p>	 <p>The first trigger signal ends the pre-trigger data recording and starts the recording of the post-trigger data. Any <b>trigger</b> received during the post-trigger data recording is ignored. Between-trigger data does not exist in this mode. The resulting sweep contains pre- and the post-trigger data.</p>
<p>Every trigger</p>	 <p>The first trigger ends the pre-trigger data recording and starts the recording of the post-trigger data. Any <b>trigger</b> received during the post-trigger data recording restarts the recording of post-trigger data. All recorded post-trigger data recorded at the time of the trigger is added to the between-trigger data. The resulting sweep contains pre-, between- and the post-trigger data.</p>
<p>Stop-trigger</p>	 <p>The trigger signal ends the pre-trigger data recording and starts the between-trigger data recording. The stop-trigger then ends the between-trigger data recording and starts the post-trigger data recording. Any <b>trigger</b> received during the between-trigger and post-trigger data recording is ignored. Any <b>stop-trigger</b> received during the pre-trigger and post-trigger data recording is ignored. The resulting sweep contains pre-, between- and the post-trigger data.</p>

### Trigger Memory Filled While Recording

The trigger memory is limited in size and can easily get filled when using High rate samples combined with high trigger rates. This section explains how triggers are handled when the trigger memory is completely filled.

Post-trigger begins on	Sweep recording selection
First trigger	A new sweep is only recorded if both pre- and post-trigger data fits in the free trigger memory at the time a trigger signal is received. When not enough free trigger memory is available, only the trigger time and trigger source get recorded (No pre- or post data is recorded).
Every trigger	A new sweep is started using the same rules as for the first trigger mode. If during the post-trigger recording a new trigger is received, the sweep is only extended with new post-trigger data if the additional post-trigger data fits the available free trigger memory. When not enough trigger memory is available, the already recorded pre-, between and post-trigger data for the previously received trigger(s) will be recorded.
Stop-trigger	A new sweep is only recorded if both pre-, 2.5 ms between and post-trigger data fits in the free trigger memory at the time a trigger signal is received. If no stop-trigger signal is received before the trigger memory fills up, the sweep recording is automatically stopped at the time the trigger memory is completely filled.

### Triggered Recording Limits

The details in this table apply to the next recording modes:

- On trigger
- On trigger - buffered with Low rate Storage disabled
- On trigger - buffered with Low rate Storage enabled

	On trigger - buffered, independent of Low rate Storage		On trigger	
Triggered data recording	Limited recording time		Use available size of drive	
Sample rate	Unlimited sample rates		Low to medium sample rates (Depending on system used)	
Channel count	Unlimited channel count		Low to medium channel counts (Depending on system used)	
<b>Maximum number of sweeps</b>				
In trigger memory	2000		Not applicable	
In PNRF recording file	200 000		1	
Sweep parameters	Minimum	Maximum	Minimum	Maximum
Pre-trigger length	0	Trigger memory of acquisition card	0	Available free drive space
Post-trigger length	0	Trigger memory of acquisition card	0	0
Sweep length	10 samples	Trigger memory of acquisition card	1 second	Available free drive space
Maximum sweeps rate	400/s		Not applicable	
Minimum time between-triggers	2.5 ms		Not applicable	
Dead time between sweeps	0 ms		Not applicable	

Data Recording Details <sup>(1)</sup>

16 Bit Resolution									
Data Recording Mode	On start of acquisition & Wait for trigger			Wait for trigger to trigger memory first			On start of acquisition reduced rate and wait for trigger to trigger memory first		
	Enabled channels			Enabled channels			Enabled channels		
	1 Ch	6 Ch	6 Ch & events	1 Ch	6 Ch	6 Ch & events	1 Ch	6 Ch	6 Ch & events
Max. trigger memory	not used			1 GS	166 MS	142 MS	800 MS	133 MS	113 MS
Max. trigger sample rate	not used			2 MS/s (GN310B) 200 kS/s (GN311B)			2 MS/s (GN310B) 200 kS/s (GN311B)		
Max. reduced FIFO	1 GS	166 MS	142 MS	not used			199 MS	33 MS	28 MS
Max. (reduced) sample rate	2 MS/s (GN310B) 200 kS/s (GN311B)			not used			Trigger sample rate / 2		
Max. aggregate reduced streaming rate	2 MS/s 4 MB/s	12 MS/s 24 MB/s	14 MS/s 28 MB/s	not used			2 MS/s 4 MB/s	12 MS/s 24 MB/s	14 MS/s 28 MB/s
18 Bit Resolution									
Data Recording Mode	On start of acquisition & Wait for trigger			Wait for trigger to trigger memory first			On start of acquisition reduced rate and wait for trigger to trigger memory first		
	Enabled channels			Enabled channels			Enabled channels		
	1 Ch	6 Ch	6 Ch & events Timer/ Counter	1 Ch	6 Ch	6 Ch & events Timer/ Counter	1 Ch	6 Ch	6 Ch & events Timer/ Counter
Max. trigger memory	not used			500 MS	83 MS	44 MS	400 MS	66 MS	35 MS
Max. trigger sample rate	not used			2 MS/s (GN310B) 200 kS/s (GN311B)			2 MS/s (GN310B) 200 kS/s (GN311B)		
Max. reduced FIFO	500 MS	83 MS	55 MS	not used			99 MS	16 MS	10 MS
Max. (reduced) sample rate	2 MS/s (GN310B) 200 kS/s (GN311B)			not used			Trigger sample rate / 2		
Max. aggregate reduced streaming rate	2 MS/s 8 MB/s	12 MS/s 48 MB/s	18 MS/s 72 MB/s	not used			2 MS/s 8 MB/s	12 MS/s 48 MB/s	18 MS/s 72 MB/s

(1) Terminology used in alignment with Perception software.

Environmental Specifications	
Temperature Range	
Operational	-20 °C to +55 °C (-4 °F to +131 °F)
Non-operational (Storage)	-25 °C to +70 °C (-13 °F to +158 °F)
Thermal protection	Automatic shutdown above +85 °C (185 °F) with notifications starting at +75 °C (+167 °F)
Relative humidity	0% to 80%; non-condensing; operational
Protection class	IP20
Altitude	Maximum 2000 m (6562 ft) above sea level; operational
Shock: IEC 60068-2-27	
Operational	Half-sine 15 g/11 ms; 3-axis, 1000 shocks in positive and negative direction
Non-operational	Half-sine 35 g/6 ms; 3-axis, 3 shocks in positive and negative direction
Vibration: IEC 60068-2-64	
Operational	2 g RMS, ½ h; 3-axis, random 5 to 500 Hz
Non-operational	3 g RMS, 1 h; 3-axis, random 5 to 500 Hz
Operational Environmental Tests	
Cold test IEC60068-2-1 Test Ad	-20 °C (-4 °F) for 2 hours
Damp heat test IEC 60068-2-3 Test Ca	+55 °C (+131 °F), humidity > 93% RH for 4 days
Non-Operational (Storage) Environmental Tests	
Cold test IEC-60068-2-1 Test Ab	-25 °C (-13 °F) for 72 hours
Dry heat test IEC-60068-2-2 Test Bb	+70 °C (+158 °F) humidity < 50% RH for 96 hours
Change of temperature test IEC60068-2-14 Test Na	-25 °C to +70 °C (-13 °F to +158 °F) 5 cycles, rate 2 to 3 minutes, dwell time 3 hours
Damp heat cyclic test IEC60068-2-30 Test Db variant 1	+25 °C/+55 °C (+77 °F/+131 °F), humidity > 95/90% RH 6 cycles, cycle duration 24 hours

**Harmonized Standards for CE and UKCA Compliance, According to the Following Directives<sup>(1)</sup>****Low Voltage Directive (LVD): 2014/35/EU****Electromagnetic Compatibility Directive (EMC): 2014/30/EU****Electrical Safety**

EN 61010-1	Safety requirements for electrical equipment for measurement, control, and laboratory use - General requirements
EN 61010-2-030	Particular requirements for testing and measuring circuits

**Electromagnetic Compatibility**

EN 61326-1	Electrical equipment for measurement, control and laboratory use - EMC requirements - Part 1: General requirements
------------	--

**Emission**

EN 55011	Industrial, scientific and medical equipment - Radio-frequency disturbance characteristics Conducted disturbance: class B; Radiated disturbance: class A
EN 61000-3-2	Limits for harmonic current emissions: class D
EN 61000-3-3	Limitation of voltage changes, voltage fluctuations and flicker in public low voltage supply systems

**Immunity**

EN 61000-4-2	Electrostatic discharge immunity test (ESD); contact discharge $\pm 4$ kV/air discharge $\pm 8$ kV: performance criteria B
EN 61000-4-3	Radiated, radio-frequency, electromagnetic field immunity test; 80 MHz to 2.7 GHz using 10 V/m, 1000 Hz AM: performance criteria A
EN 61000-4-4	Electrical fast transient/burst immunity test Mains $\pm 2$ kV using coupling network. Channel $\pm 2$ kV using capacitive clamp: performance criteria B
EN 61000-4-5	Surge immunity test Mains $\pm 0.5$ kV/ $\pm 1$ kV Line-Line and $\pm 0.5$ kV/ $\pm 1$ kV/ $\pm 2$ kV Line-earth Channel $\pm 0.5$ kV/ $\pm 1$ kV using coupling network: performance criteria B
EN 61000-4-6	Immunity to conducted disturbances, induced by radio-frequency fields 150 kHz to 80 MHz, 1000 Hz AM; 10 V RMS @ mains, 3 V RMS @ channel, both using clamp: performance criteria A
EN 61000-4-11	Voltage dips, short interruptions and voltage variations immunity tests Dips: performance criteria A; Interruptions: performance criteria C

- (1)  The manufacturer declares on its sole responsibility that the product is in conformity with the essential requirements of the applicable UK legislation and that the relevant conformity assessment procedures have been fulfilled.

Manufacturer:

**Hottinger Brüel & Kjaer GmbH**  
Im Tiefen See 45  
64293 Darmstadt  
Germany

Importer:

**Hottinger Brüel & Kjaer UK Ltd.**  
Technology Centre Advanced Manufacturing Park  
Brunel Way Catcliffe  
Rotherham  
South Yorkshire  
S60 5WG  
United Kingdom

Artificial Star Adapter Wiring Diagram

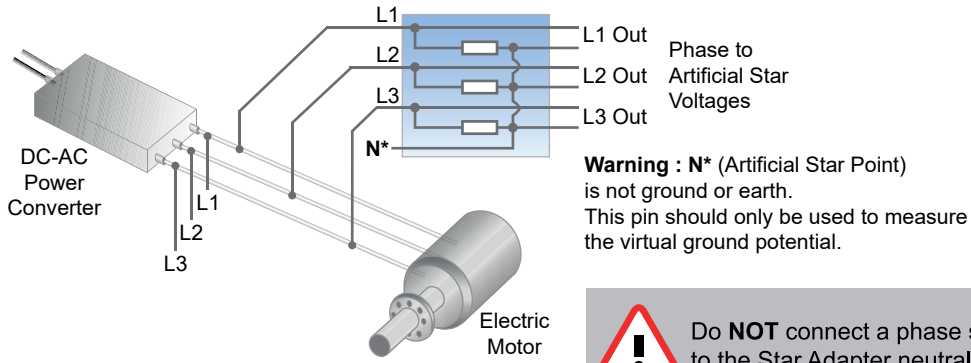

Figure 42: Three phase representative use of artificial star adapter

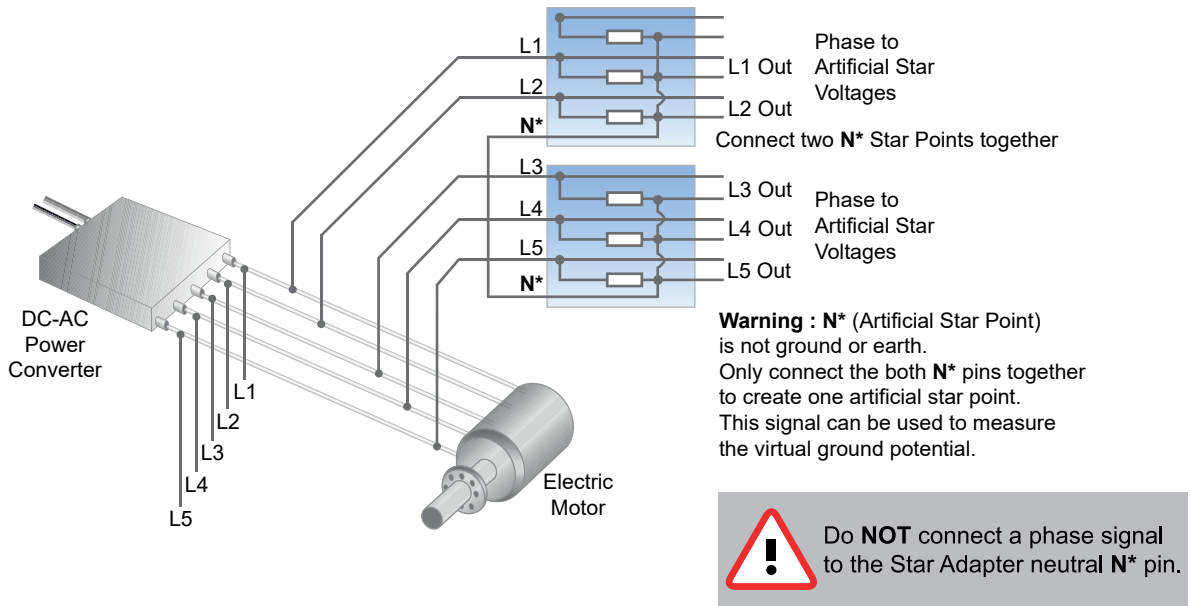

Figure 43: Five or more phase representative use of dual star adapter

## Perception and eDrive Training Program



Figure 44: Perception on-site training

HBM offers paid professional training and support programs on all API interfaces (PNRF reader, RPC and CSI). Training programs are based on C#, are on-site or are at a central HBM location. On-site training can be specific for each customer. Support can be the development of a fully customized software application or answering questions from software engineers.

S-TRAIN1-GEN_PERC	First day on-site basic training on GEN DAQ/PERCEPTION. Example content: Basic usage, hardware setup, acquisition. Training can be customized for specific training needs.
S-TRAIN2-GEN_PERC	Second day on-site enhanced training on GEN DAQ/PERCEPTION. Training can be customized for specific training needs.
S-TRAIN1-eDRIVE	First day on-site basic training on eDrive application specifics. Example content: Basic usage, hardware setup, acquisition. Training can be customized for specific training needs.
S-TRAIN2-eDRIVE	Second day on-site enhanced training on eDrive application specifics. Training can be customized for specific training needs.
1-PERC-CSI-TRAIN	Two day on-site Perception CSI training for software programmers During the training software programmers learn how to get started using the CSI template, make changes to the Perception user interface, to add new mathematical routines to the Formula Database or to add User Keys etc. The exact training details can be fully customized to the programmers needs including reviews and examples how to create the exact CSI changes of choice. Basic Microsoft® Visual Studio software C# programming skills are required before joining this training. More dedicated detailed training is available on request.
1-PERC-CSI-PROJ	One day eMail/Phone support for Perception CSI or RPC programmers. Get support from a HBM senior software engineer. Support can range anywhere from answering "how-to" question, assisting in analyzing any kind of (performance) issue to generating basic getting started example code fragments.

**Calibration Service**

HBK offers a wide range of calibration services. Check your local sales contact for more information.  
HBK recommends yearly recalibration of all systems and transducers.

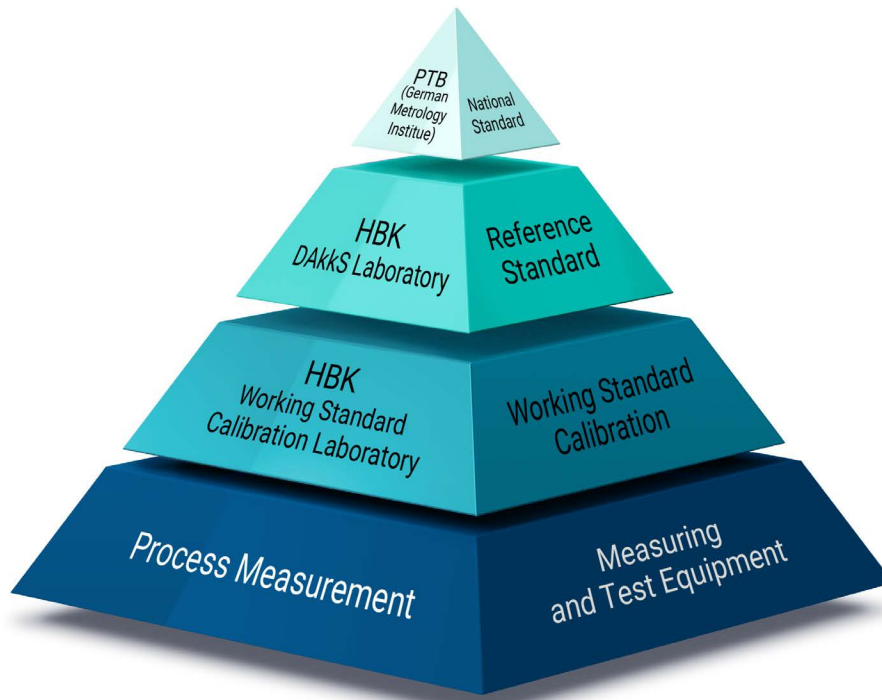

Figure 45: HBK calibration process

GN310B/GN311B HBM Current Transducer (CT) Wire Diagram

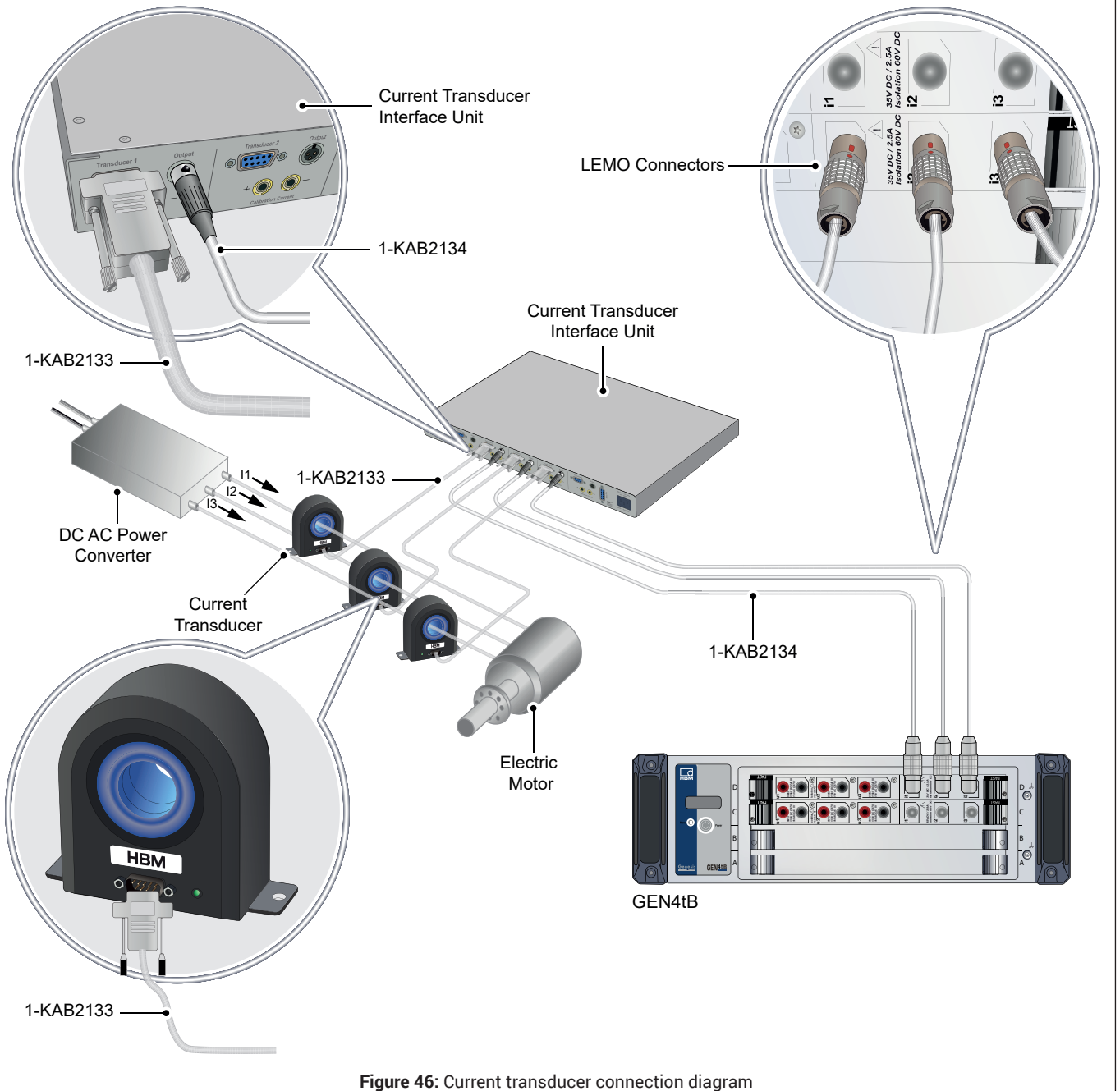

Figure 46: Current transducer connection diagram

**Current Transducers, to be ordered separately**

Ultra-stable, high precision fluxgate technology current transducers for non-intrusive, isolated measurement





Figure 47: HBM current transducers, power supply and cables

**Current Transducer Family Overview**



Type	Maximum current	Bandwidth (-3 dB)	Aperture size	Supported by P112I-4	Supported by 1-CTPSIU-6-1U	Order No.
CTS50ID	75 A DC / 50 A RMS	1000 kHz	27.6 mm	Yes	Yes	1-CTS50ID
CTS200ID	300 A DC / 200 A RMS	500 kHz	27.6 mm	Yes	Yes	1-CTS200ID
CTS400ID	600 A DC / 400 A RMS	300 kHz	27.6 mm	Yes	Yes	1-CTS400ID
CTS600ID	900 A DC / 600 A RMS	500 kHz	27.6 mm	Yes	Yes	1-CTS600ID
CTM1200ID	1500 A DC / 1200 A RMS	400 kHz	45.0 mm	No	Yes	1-CTM1200ID
CTN1000ID	1500 A DC / 1000 A RMS	400 kHz	41.0 mm	Yes <sup>(1)</sup>	Yes	1-CTN1000ID

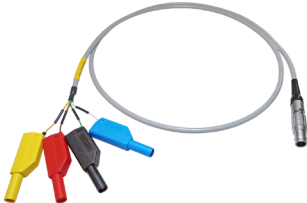

(1) Approved for use only up to nominal current levels of 1000 A DC / 1000 A RMS. Above these levels additional noise can occur.



**Current Transducers Interface and Cables, to be ordered separately**

Article	Description	Order No.
CT Interface unit	 <p>Interface unit for up to six current transducers. Industry standard D-SUB 9 pin input connectors. Multi-pin XLR output connectors. Supports transducer calibration winding access through 4 mm spring-loaded safety plugs. Front LEDs to indicate normal operation of each transducer. 100 - 240 V AC 50/60 Hz AC input voltage. 120 - 370 V DC input voltage. 1U height 19" rack mountable.</p>	1-CTPSIU-6-1U
CT cables	 <p>Industry standard current transducer connection cable. Shielded, low ohmic 9 wire cable with D-Sub 9 connectors on both ends. Supports power, status, current output and calibration current input. Lengths: 0.5, 1, 2, 5, 10 and 15 m (1.65, 3.28, 6.56, 16.4, 32.8 and 49.2 ft)</p>	1-KAB2133-0.5 1-KAB2133-1 1-KAB2133-2 1-KAB2133-5 1-KAB2133-10 1-KAB2133-15
Banana input cable	 <p>Shielded cable for 1-GN31xB current channels. LEMO breakout cable with direct current (blue), voltage as current (red), isolated ground/return (black) and shield (yellow) 4 mm banana connectors. The cable is shielded to minimize the typical impact of electromagnetic disturbance generated by high power switching power supplies. Available length: 1 m (3.3 ft)</p>	1-KAB2136-1





## Current Probes (Options, to be ordered separately)

Article	Description	Order No.
AC/DC current clamp i30s	 <p>AC/DC Hall effect current probe; 30 mA to 30 A DC; 30 mA to 20 A AC RMS; DC-100 kHz; BNC output cable 2 m (6.5 ft), incl. adapter for 4 mm safety banana, requires 9 V battery.</p>	1-G912
AC current clamp SR661	 <p>AC current probe; 100 mA to 1200 A AC RMS; 1 Hz - 100 kHz; safety BNC output cable 2 m (6.5 ft).</p>	1-G913
AC current clamp M1V20-2	 <p>Highly accurate AC current probe; 50 mA to 20 A; 30 Hz - 40 kHz; metal BNC output cable 2 m (6.5 ft).</p>	1-G914

Ordering Information			
Article		Description	Order No.
Isolated Power Analyzer 2 MS/s		<p>Input card with 3 power channels (Voltage &amp; Current) supporting 18 bit ADCs at 2 MS/s and 2 GB memory.</p> <p>Voltage inputs range from <math>\pm 50</math> V to <math>\pm 1500</math> V DC. Current inputs using built-in shunts range from <math>\pm 75</math> mA to <math>\pm 2</math> A or <math>\pm 50</math> mV to <math>\pm 20</math> V for current clamp usage.</p> <p>Tested up to 7.4 kV, the isolation allows for safe measurements up to 1000 V CAT IV or 1500 V DC. Voltage inputs use 4 mm fully isolated banana plugs while current inputs use a LEMO connector.</p> <p>Includes the real-time formula data base for sample to sample as well as cycle based calculations and triggering on calculated results.</p> <p>Supported by Perception v8.00 and higher.</p>	1-GN310B
Isolated Power Analyzer 200 kS/s		<p>Input card with 3 power channels (Voltage &amp; Current) supporting 18 bit ADCs at 200 kS/s and 2 GB memory.</p> <p>Voltage inputs range from <math>\pm 50</math> V to <math>\pm 1500</math> V DC. Current inputs using built-in shunts range from <math>\pm 75</math> mA to <math>\pm 2</math> A or <math>\pm 50</math> mV to <math>\pm 20</math> V for current clamp usage.</p> <p>Tested up to 7.4 kV, the isolation allows for safe measurements up to 1000 V CAT IV or 1500 V DC. Voltage inputs use 4 mm fully isolated banana plugs while current inputs use a LEMO connector.</p> <p>Includes the real-time formula data base for sample to sample as well as cycle based calculations and triggering on calculated results.</p> <p>Supported by Perception v8.00 and higher.</p>	1-GN311B

Special Voltage Probes, to be ordered separately			
Article		Description	Order No.
5 kV RMS, 20 M $\Omega$ , 50:1 differential probe		<p>5 kV RMS, 20 M<math>\Omega</math>, 50:1, 0.2% high precision, differential probe to be used in combination with GN610B, GN611B (HVD50R-61x), GN310B and GN311B (HVD50R-31x) acquisition cards. The built-in earthing monitor system increases safety of the user and protects the GEN series inputs for isolation overloads.</p>	HVD50R-61x HVD50R-31x Ordered from custom systems <sup>(1)</sup>
5 kV RMS High Voltage Cable		<p>The High Voltage Cable (HVC) is an extension for measurement cables with voltages up to 5 kV RMS. This device is designed to be connected with a cable on the input terminal of the high precision differential probe HVD10, HVD50R-61x and HVD50R-31x.</p> <p>The HVC is designed according IEC 61010-031:2015 compliant to 1000 V RMS CAT IV and 1500 V DC CAT IV.</p>	HVC Ordered from custom systems <sup>(1)</sup>

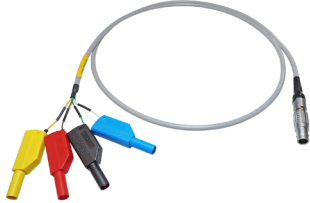
(1) Contact custom systems at: [customsystems@hbkworl.com](mailto:customsystems@hbkworl.com)  
Request quote/information for special products for GEN series.

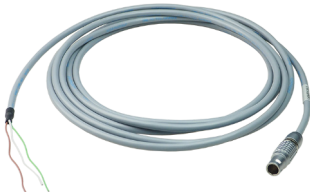
Accessories, to be ordered separately		
Article	Description	Order No.
Artificial star adapter	 The artificial star adapter is a plug-on interface card to measure 3-phase signals with the GN310B/GN311B cards. This adapter is intended for measuring 3-phase signals while creating a virtual/artificial star point.	1-3PH-STR-1K0-CAT2
1000 V CAT IV / 1500 V DC CAT III 3-wire Isolated shielded test leads	 The cable uses safety-shrouded banana plugs for: <ul style="list-style-type: none"> <li>3-phase measurement (Black/Brown/Grey) or single-phase neutral to line</li> <li>Shield connector (Yellow)</li> </ul> The cable is shielded to minimize the typical impact of electromagnetic disturbance generated by high-power inverters, as well as to minimize emissions from the rise times of the switching inverter voltages measured with this cable. Available lengths: 1.5 m (4.92 ft), 3.0 m (9.84 ft), 6.0 m (19.7 ft), 12 m (39.4 ft), 20 m (65.6 ft)	1-KAB2139-1.5 1-KAB2139-3 1-KAB2139-6 1-KAB2139-12 1-KAB2139-20
XLR to LEMO cable for GN31XB	 CT interface unit to GN31xB DAQ power card connection cable. Uses XLR and LEMO connectors for a direct current output connection to the GEN DAQ card. Length 2 m (6 ft)	1-KAB2134-2
Banana input cable	 Shielded cable for 1-GN31xB current channels. LEMO breakout cable with direct current (blue), voltage as current (red), isolated ground/return (black) and shield (yellow) 4 mm banana connectors. The cable is shielded to minimize the typical impact of electromagnetic disturbance generated by high power switching power supplies. Available length: 1 m (3.3 ft)	1-KAB2136-1
Female BNC voltage input cable	 Shielded cable for 1-GN31xB current channels in voltage mode. LEMO breakout cable with female BNC for ease of connecting e.g. current probes. The female BNC is connected to the Voltage input pin of the current channel. The cable is one side shielded to minimize the typical impact of electromagnetic disturbance generated by high power switching power supplies.	1-KAB2140-3
Male BNC voltage input cable	 Shielded cable for 1-GN31xB current channels in voltage mode. LEMO breakout cable with male BNC for ease of connecting e.g. current probes. The male BNC is connected to the Voltage input pin of the current channel. The cable is one side shielded to minimize the typical impact of electromagnetic disturbance generated by high power switching power supplies. Available length: 2 m (6.6 ft)	1-KAB2137-2
Open end input cable	 Shielded cable for 1-GN31xB current channels. LEMO breakout cable with direct current, voltage as current, isolated ground/return and shield open end cables (the individual wires are labeled). Can be used to add custom connectors and/or soldered to measurement points. The cable is shielded to minimize the typical impact of electromagnetic disturbance generated by high power switching power supplies. Available length: 3 m (9.8 ft)	1-KAB2138-3

**Hottinger Brüel & Kjaer GmbH**

Im Tiefen See 45 · 64293 Darmstadt · Germany  
Tel. +49 6151 803-0 · Fax +49 6151 803-9100  
[www.hbkworld.com](http://www.hbkworld.com) · [info@hbkworl.com](mailto:info@hbkworl.com)

Subject to modifications. All product descriptions are for general information only.  
They are not to be understood as a guarantee of quality or durability.