

DESIGNLIFE

Fatigue Life Prediction and Test-CAE Correlation

nCode DesignLife is a CAE-based fatigue analysis system that contains a comprehensive set of solvers and advanced methods for predicting structural durability from major finite element analysis (FEA) result files.

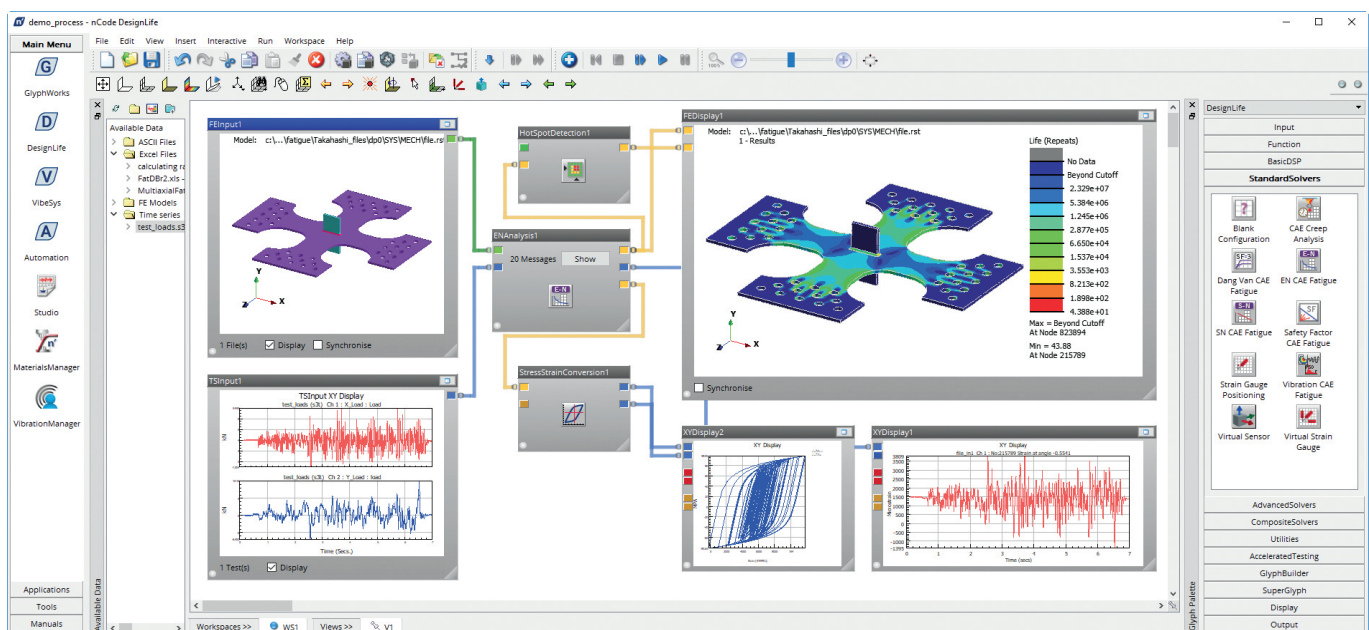

BENEFITS

- Reduce reliance on physical tests and avoid costly design and tooling changes
- Perform smarter and quicker physical tests by simulating first
- Decrease warranty claims by reducing failures
- Reduce cost and weight by assessing more design options
- Improve consistency and quality with standardised analysis processes and reporting

Core functionality for advanced fatigue analysis

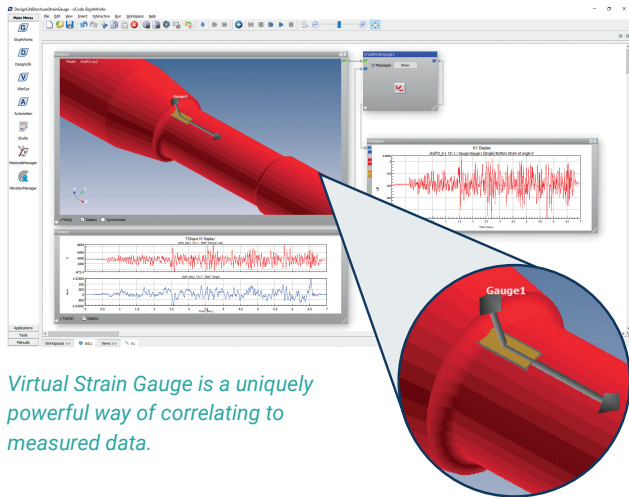

Virtual Strain Gauge is a uniquely powerful way of correlating to measured data.

VIRTUAL STRAIN GAUGE AND VIRTUAL SENSOR

Enable correlation between test and finite element results. Gauges (single or rosette) or displacement sensors may be graphically positioned and oriented on finite models as a post-processing step. Time histories due to applied loads can be extracted for direct correlation with measured strain, force, displacement, acceleration and velocity data. PSDs of displacement, velocity or acceleration can also be extracted based in finite element displacements and PSD loading.

CRACK GROWTH

Provides a complete fracture mechanics capability using industry standard methodologies for specified locations on the FE model. Built-in growth laws include NASGRO, Forman, Paris, Walker and more. Select from a provided library of geometries or supply custom stress intensity factors.

FE-DISPLAY

Enables the graphical display of FE models with contours of stress results. Animating displacements from FE results or animation files display structural deformation under load.

STRESS-LIFE ANALYSIS

Enables fatigue life prediction of high-cycle fatigue where nominal stress controls the fatigue life. Includes the ability to interpolate between material curves depending on the temperature.

nCode DesignLife provides the ability to go beyond performing simplified stress analysis and avoid over-designing products by simulating actual loading conditions to avoid costly design changes.

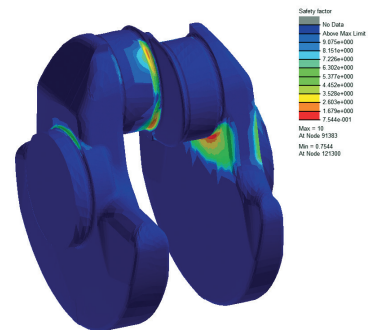

CUSTOM ANALYSIS

Enables Python or MATLAB scripts to be used to extend existing analysis capabilities – perfect for proprietary methods or research projects.

SIGNAL PROCESSING

nCode Fundamentals is included for basic data manipulation, analysis and visualisation. Duty cycles can be defined by selecting from and building multiple cases. This feature makes it easy to create a composite duty cycle with repeats.

MATERIALS MANAGER

Enables material data to be added, edited and plotted. A standard database with over 450 in-house validated fatigue properties for many commonly used materials is included. A Premium Materials Database containing over 140 fatigue parameters for steels and aluminium alloys available for add-on.

VIBRATION MANAGER

Enables vibration specification data to be entered, edited, and viewed. A standard database with over 100 vibration entries is included.

DesignLife options

STRESS-LIFE (SN)

The primary application of the Stress-Life method is high-cycle fatigue (long lives) where nominal stress controls the fatigue life. A wide range of methods are provided for defining the SN curves, including the ability to interpolate multiple material data curves for factors such as mean stress or temperature. Further options are also provided to account for stress gradients and surface finishes. For ultimate flexibility, Python scripting enables the definition of custom fatigue methods and material models.

FEATURES INCLUDE

- Material models
 - Standard SN
 - SN Mean multi-curve
 - SN R-ratio multi-curve
 - SN Haigh multi-curve
 - SN Temperature multi-curve
 - Bastenaire SN
 - Custom SN using Python scripting
- Stress combination methods or critical plane analysis
- Back calculation to target life
- Multiaxial assessment
 - Biaxial
 - 3D Multiaxial
 - Auto-correction
- Mean stress corrections
 - FKM Guidelines
 - Goodman
 - Gerber
 - Walker
 - Interpolate multiple curves
- Notch Correction
 - Stress gradient corrections
 - FKM Guidelines
 - User defined
 - Critical distance

STRAIN-LIFE (EN)

The Strain-Life method is applicable to a wide range of problems including low-cycle fatigue where the local elastic-plastic strain controls the fatigue life. The standard EN method uses the Coffin-Manson-Basquin formula, defining the relationship between strain amplitude ϵ_a and the number of cycles to failure N_f . Material models can also be defined using general look-up curves. This enables the ability to interpolate multiple material data curves for factors such as mean stress or temperature.

FEATURES INCLUDE

- Material models
 - Standard EN
 - EN Mean multi-curve
 - EN R-ratio multi-curve
 - EN Temperature multi-curve
 - EN Gray Iron
- Strain combination methods or critical plane analysis
- Stress-strain tracking for accurate cycle positioning
- Back calculation to target life
- Multiaxial damage models
 - Wang Brown
 - Wang Brown with Mean
 - Brown Miller
 - Brown Miller with Mean
- Mean stress corrections
 - Morrow
 - Smith Watson Topper
 - Interpolate multiple curves
- Plasticity corrections
 - Neuber
 - Hoffman-Seeger
 - Seeger-Heuler
- Multiaxial assessment
 - Biaxial
 - 3D Multiaxial
 - Auto-correction

Efficiently locate critical failures of joint materials

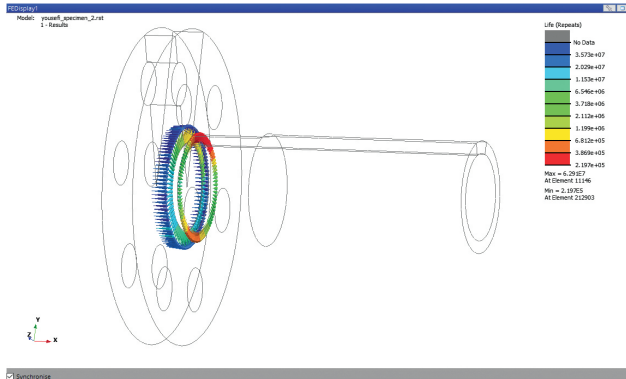

SEAM WELD

The Seam Weld option enables the fatigue analysis of seam welded joints, including fillet, overlap and laser welds. The method is based on the approach developed by Volvo (see SAE paper 982311) and validated through years of use on vehicle chassis and body development projects. Seam weld analysis can be carried out with all load types including vibration. Stresses can either be taken directly from FE models (shell or solid elements) or calculated from grid point forces or displacements at the weld.

DesignLife provides methods to intelligently identify weld lines in the FE model, thus simplifying the process of setting up the fatigue job. General material data for seam welds for both bending and tension conditions are supplied with the software. The approach is appropriate for weld toe, root and throat failures.

Thick welds are assessed using the stress integration method outlined in ASME Boiler & Pressure Vessel Code VIII (Division 2) standard. This now features an automated method to identify the weld locations from the solid FE model. Corrections are also available for sheet thickness and mean stress effects. The structural stress at the weld toe, the hot-spot stress, can be also be estimated by the extrapolation of the surface stress at points near the weld. The BS7608 welding standard is also supported, together with required material curves.

WHOLELIFE

WholeLife delivers a more accurate determination of weld lives particularly for complex geometries by using an integrated approach for modelling fatigue over the entire lifetime of a component – from the very early stages to final fracture. The same structural stress technique used for seam welds is used in WholeLife to determine the structural bending and membrane stresses at the weld. WholeLife uses the through thickness stress distribution for the geometry and can include the effect of a known residual stress profile. Although this is primarily a CAE-based analysis, the same method may also be applied to measured stress data.

SPOT WELD

Based on the LBF method (SAE paper 950711), the approach enables fatigue analysis of spot welds in thin sheets. The spot welds are modelled by stiff beam elements (for example, NASTRAN CBAR) and the creation of these welds in this form is supported by many leading FE pre-processors. CWELD and ACM formulations using solid element representation are also supported. Related model information is automatically identified, allowing quick and simple job setup and solutions. Cross-sectional forces and moments are used to calculate structural stresses around the edge of the weld. Life calculations are made around the spot weld at multiple angle increments and the total life reported includes the worst case. The provided materials data can be applied to many spot weld cases. Python scripting enables modelling of other joining methods such as rivets or bolts.

ADHESIVE BONDS

This fracture mechanics-based method assesses which joints in the structure are most critically loaded. Adhesive bonds are modelled with beams or solid elements and grid point forces are used to determine line forces and moments at the edge of the glued flange. Approximate calculations of the strain energy release rate (the equivalent J-integral) can be made at the edge of the adhesive and, by comparison to the crack growth threshold, a safety factor (design reserve factor) may also be calculated.

DesignLife options

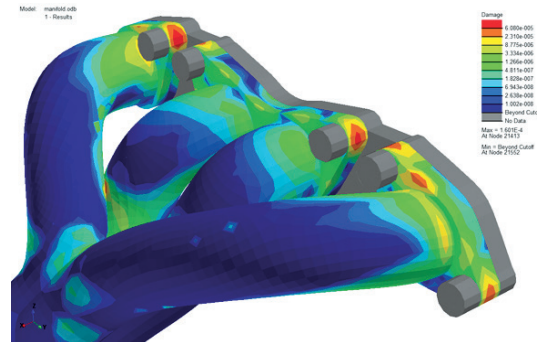
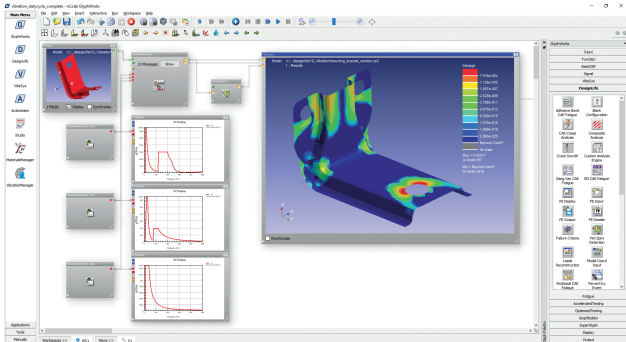

VIBRATION FATIGUE

The Vibration Fatigue option enables the simulation of vibration shaker tests driven by random (PSD), swept-sine, sine-dwell or sine-on-random loading. It provides the capability to predict fatigue in the frequency domain and it is more realistic and efficient than time-domain analysis for many applications with random loading such as wind and wave loads. Finite element models are solved for frequency response or modal analysis and the vibration loading is defined in DesignLife. This can include the effect of temperature, static offset load cases and complete duty cycles of combined loading. Vibration fatigue loads can be used for Strain-Life (EN), Stress-Life (SN), Spot Weld, Seam Weld and Short Fibre Composite analyses.

The multi-load vibration option allows the use of multiple random input PSDs and cross-spectra for the analysis of structures with multiple load application points and/or directions. This option also includes the Frequency Response Analysis glyph to convert time series input into the required spectra and cross spectra.

Vibration Profile Design (formerly Accelerated Testing) is the perfect add-on product for Vibration Fatigue. It has the ability to create a representative PSD or swept-sine shaker vibration test based on measured data. It enables the combination of multiple time or frequency domain data sets into representative test spectra that accelerates the test without exceeding realistic levels.

THERMO-MECHANICAL FATIGUE

Components in high temperature operating environments such as engine pistons, exhaust systems and manifolds can suffer from complex failure modes. The Thermo-Mechanical Fatigue (TMF) option provides solvers for high temperature fatigue and creep by using stress and temperature results from finite element simulations. Mechanical loads that vary at a different rate to the temperature variations can also be combined. Required material data is derived from standard constant temperature fatigue and creep tests.

TMF includes high temperature fatigue methods Chaboche and ChabocheTransient. Creep analysis methods include Larson-Miller and Chaboche creep.

STRAIN GAUGE POSITIONING

The Strain Gauge Positioning glyph calculates the optimum position and number of gauges required to enable the subsequent reconstruction of applied load histories.

The Loads Reconstruction glyph uses the virtual strains created by unit loads along with the measured strain histories from gauges matching the virtual gauges to reconstruct the force histories that caused the measured strains.

DesignLife product options for the analysis of composite materials

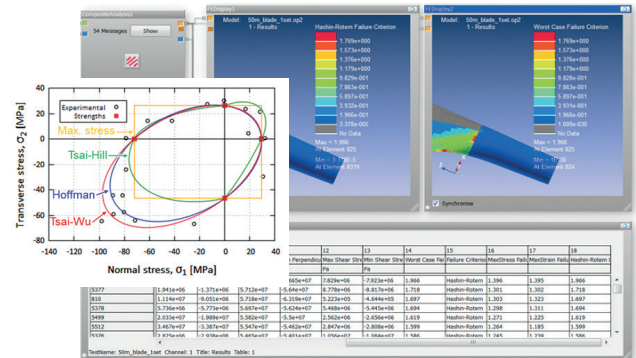
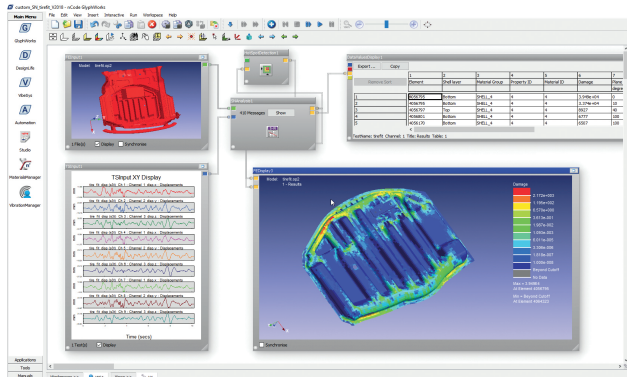

SHORT FIBRE COMPOSITE

The Short Fibre Composite option uses a stress-life approach for the analysis of anisotropic materials such as glass fibre filled thermoplastics. The stress tensor for each layer and section integration point throughout the shell thickness is read from FE results. The material orientation tensor describing the 'fibre share' and direction at each calculation point is provided by mapping a manufacturing simulation to the finite element model. This orientation tensor can be read from the FE results file or supplied from an ASCII file.

The Short Fibre Composite analysis requires standard materials data of two or more SN curves for differing fibre orientations. DesignLife uses this data to calculate an appropriate SN curve for each calculation point and orientation. DesignLife capabilities such as multiple variable amplitude loads and duty cycles are also supported for composites.

COMPOSITE ANALYSIS

The Composite Analysis option allows users to evaluate the strength of a structure against industry standard composite failure criteria. Rather than limiting this evaluation to a small number of load cases or steps, stresses can be assessed using the chosen failure criteria throughout realistic duty cycles (quasi-static or dynamic). This allows critical locations, load combinations and associated design reserve factors to be readily identified. In addition, selected location loading paths may be visually compared with the material failure envelope.

The following methods can be used individually or combined to give the most conservative result:

- Maximum stress
- Maximum strain
- Norris
- Hoffman
- Tsai-Hill
- Tsai-Wu
- Franklin-Marin
- Hashin
- Hashin-Rotem
- Hashin-Sun
- Modified NU
- Norris-McKinnon
- Christensen
- Unit Circle
- User-defined custom methods via Python

DesignLife options

DANG VAN

Dang Van is a multiaxial fatigue limit criterion used to predict the endurance limit under complex loading situations. The output from the analysis is expressed as a safety factor and not a fatigue life. It uses specific material parameters calculated from tensile and torsion tests. Manufacturing effects can also be accounted for by using equivalent plastic strain in the unloaded component. As well as the standard Dang Van method it can also be used for spot welds and can use Dang Van multi-temperature materials data.

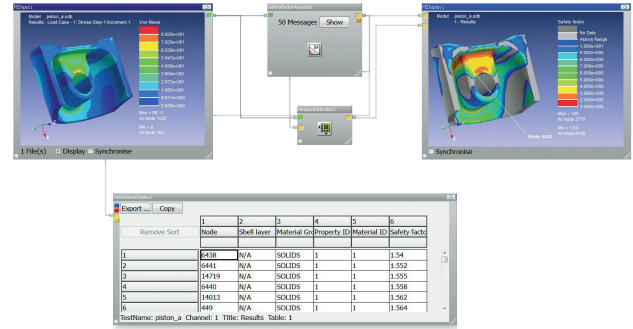

SAFETY FACTOR

Safety Factor enables the calculation of stress-based factors of safety. It uses standard mean stress corrections or user-specified Haigh diagrams to assess durability. This method is widely used as a key design criteria for engine and powertrain components.

RAPIDLY IMPROVE DESIGNS BY TAKING ADVANTAGE OF HARDWARE SCALABILITY

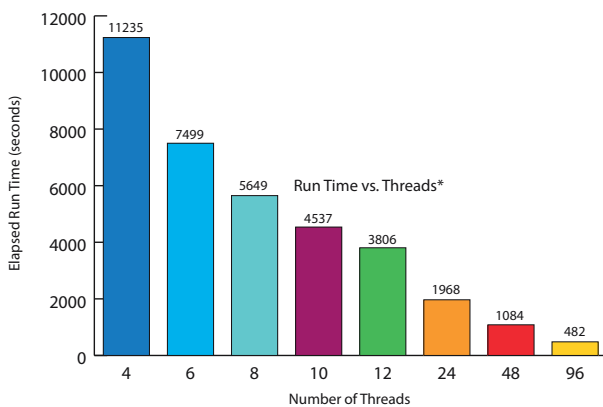
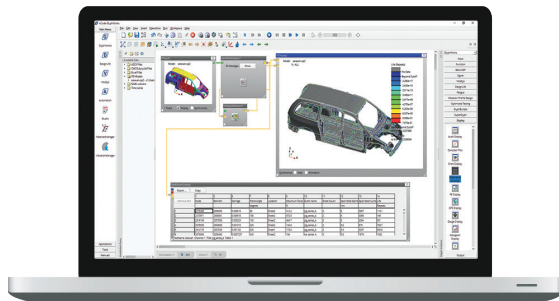

**Actual reduction in run time depends on specific job
Increase simulation throughput by adding computing resources*

PROCESSING THREAD OPTION

DesignLife can parallel process on machines with multiple processors. Each Processing Thread license allows another core to be utilised. Since the fatigue calculation at each model location is effectively independent, the benefit to adding additional processing threads is very scalable. This option means spending less time to go directly from raw inputs to finished results. Multiple threads can also be used to speed up the translation phase of the analysis by splitting the translation into multiple processes.

DISTRIBUTED PROCESSING OPTION

Distributed Processing enables an analysis running in batch mode to be distributed across multiple computers or nodes of a compute cluster. It uses the MPI standard common in high performance computing environments so that even the largest of finite element simulations can be completed efficiently. This scalability enables you to rapidly solve jobs by using the combined processors of many machines.

EXPLORE OTHER NCODE SOLUTIONS

nCode GlyphWorks

Data processing system for signal processing and durability analysis.

nCode VibeSys

Data processing system for vibration analysis.

Aqira

Standardise engineering processes, perform streamed data analytics, and manage data.

Premium Materials Database

High-quality fatigue parameters of steels, aluminium alloys, and additive manufacturing materials.

ABOUT US

We help engineers deliver durable and reliable products and avoid the cost of unexpected failures. Our software brands for durability and reliability, nCode and ReliaSoft, empower data-driven confidence through accurate analysis and simulation, enabling customers to achieve success through failure prediction.

For more information, please visit: www.hbkworld.com

HBK – Hottinger Brüel & Kjær

www.hbkworld.com

info@hbkworl.com

© 2024 Hottinger Brüel & Kjær Inc. All rights reserved. All other product names, logos, trademarks, and service marks are the property of their respective owners.